

- Thank you for choosing EPS1 series AC servo motor driver
- Please read the manual carefully before using the driver and follow the instructions.

## ● Safety Notification ●



(Please read carefully before using the driver)

Please read the manual carefully for installation, operation, maintenance and inspection. Make sure knowing the related information about the instruments, safety issues and all other notifications before using the drive. Please keep this manual properly for reference. Please contact us when you can not solve any problem.

- Some modification in the manual may not be notified for product improvement and update.
- Our company is not responsible for the customer's modification to the product without our authorization and the warranty will end accordingly.

Please pay attention to the following cautions to avoid personal injury or device damage.

- The following "DANGER" and "CAUTION" are listed based on their dangerous level.

	<b>DANGER</b> Indicates a potentially hazardous situation which, if not avoided, will result in death or serious injury.
	<b>CAUTION</b> Indicates a potentially hazardous situation which, if not avoided, will result in minor injury or property damage.

The following symbols represent "MUST NOT" or "MUST" operations which you have to observe.



Represents "MUST" operation which has to be executed.



Represents "MUST NOT" operation which is inhibited.

# CAUTION

**Install an emergency stop circuit externally so that you can stop the operation and shut off the power immediately.**



Failure to observe this instruction could result in injuries, electrical shocks, fire, breakdowns and damages.

**Do not place water, combustibles or caustics near the driver.**



Failure to observe this instruction could result in fire.

**Servo motor driver and servo motor should be grounded safely.**



Failure to observe this instruction could result in electrical shocks.

**Don't put your figure inside the driver.**



Failure to observe this instruction could result in injuries and electrical shocks.

**Wait at least ten minutes after shutting off the power for driver movement, wire connection and inspection.**



Failure to observe this instruction could result in electrical shocks.

**For the trial run, connect the motor without the load.**



Failure to observe this instruction could result in component damage.

**Choose and use the correct rated voltage.**



Failure to observe this instruction could result in electrical shock, damage and fire.

**Do not modify, disassemble or repair the driver by yourself.**



Failure to observe this instruction could result in electrical shock or injury.

**Make sure the circuit is connected correctly and properly.**



Failure to observe this instruction could result in electrical shock or fire.

# Content

## Chapter 1 Functions and Configuration

- 1.1 EPS1 Series Driver Technical Specs
- 1.2 EPS1 Series Driver Functions
- 1.3 Name Plate for EPS1 Series Driver
- 1.4 EPS1 Series Driver Dimensions
- 1.5 EPS1 Series Driver Compatible Motor
- 1.6 Parts Description

## Chapter 2 Installation

- 2.1 Environmental Conditions
- 2.2 Installation Place
- 2.3 Mounting Orientation and Space
- 2.4 Motor Installation
- 2.5 Servo Motor Driver Installation Figures
- 2.6 Cable Stress

## Chapter 3 Wiring

- 3.1 Driver Configuration and Connection to Peripheral Device
- 3.2 Standard Connection
- 3.3 Terminal Functions
- 3.4 I/O Interface
- 3.5 Power Supply Circuit

## Chapter 4 Parameters

- 4.1 Parameter Overview

## 4.2 Parameter Function

## Chapter 5 Monitoring and Operation

### 5.1 Panel Operation

### 5.2 Monitoring Mode (DISP)

### 5.3 Parameter Setup (SET-PA)

### 5.4 Parameter Management (EEP-OP)

### 5.5 Speed Trial Run

## Chapter 6 Alarm and Handling

### 6.1 Driver Alarm

### 6.2 Alarm Handling

## Chapter 7 Servo Motor

### 7.1 Model Naming Format

### 7.2 Motor Installation Dimension

## Appendix

# Chapter 1 Functions and Configuration

## 1.1 EPS1 Series driver technical specs

Table 1.1 Driver Technical Specs

<b>Control Circuit Power Supply</b>		Single Phase AC220V -15~+10% 50 / 60Hz	<b>Main Circuit Power Supply</b>	3/single-phase AC220V -15~+10% 50 / 60Hz
<b>Ambient</b>	<b>Temperature</b>	Operation: 0~55℃ Storage: -20℃~80℃		
	<b>Humidity</b>	<90% ( free from condensation)		
	<b>Vibration</b>	<0.5G(4.9m/S <sup>2</sup> ), 10~60Hz (non-continuous operation)		
<b>Control Method</b>		IGBT PWM sinusoidal waveform control		
<b>Control Mode</b>		①Position control ②Speed control ③Torque control ④Position/speed control⑤Position/Torque Control ⑥Speed/Torque Control ⑦Internal position control ⑧Internal speed control⑨ Internal torque control		
<b>Control Input</b>		① Servo control enable ② Fault clear ③ Initial position error clear ④ Command pulse disable ⑤ CCW driver disable ⑥ CW driver disable⑦ Control mode selection ⑧ zero speed clamp		
<b>Control Output</b>		① Servo ready ② Servo alarm ③ Mechanical brake release ④ Position / Speed arrival ⑤ Zero-speed detection ⑥ Torque limit ⑦ Phase-Z output		
<b>Encoder(Speed Sensor) Feedback</b>		2500p/r, 15 resolution incremental encoder, differential output 500 p/r, 15 resolution incremental encoder, differential output		
<b>Communication method</b>		①RS232 ②RS485		
<b>Display and operation</b>		①5-bit LED display ② 4 buttons		
<b>Brake method</b>		Internal/External braking resistor		
<b>Cooling method</b>		Air cooling (Heat conductive material、High speed cooling fan)		
<b>Motor model</b>		Compatible for various type of motors (by adjusting the system parameters)		
<b>Power range</b>		≤5KW		

1. 2 SC Series Driver Functions

Table 1.2 Driver function overview

Control Functions	Position Control	External input pulse	Pulse/direction, CW/CCW, A/B 2-phase
		Maximum command pulse frequency	500Kpps (differential input)
		Electrical gear	1/1800~1800 (Recommend: 1/50~50)
		Command pulse input disable	Command pulse input is disabled when the corresponding bit is effective and can be set through parameters.
		Internal position command	16 kinds of position setting
	Speed Control	External speed reference	0~±10V DC
		Zero speed clamp	Speed is controlled to zero by this function.
		Speed control range	1~3000
		Internal speed reference	4 kinds of speed reference setting
	Torque Control	External torque command	0~±10V DC
		Internal torque command	4 kinds of torque setting
		Torque control range	External torque command: 0~300% Internal torque command: 0~300%
	Drive disable	When signal CCWL/CWL is active, motor keeps zero-speed and maintains the torque in CCW/CW direction.	
Monitoring function	Speed, position, command pulse accumulation, position error, motor torque, motor current, rotor position, command pulse frequency, operation status, input/output terminal signal		
Protection function	Over-voltage, low-voltage, over-current, over-speed, over-load, Z-pulse missing, encoder error, EEPROM error, position error exceed.		
Alarm function	Output alarm signal when abnormal operation happens. All 5 LEDs' decimal points keep blinking at the same time.		
Signal display	ON/OFF status of the I/O signal are displayed		
Gain tuning	Gain can be adjusted to improve the motor performance when motor is running or stop.		
Alarm record	4 alarm records including the present one are memorized.		

1. 3 Name plate for EPS1 series driver

**EPS-T A 075 L 1 21**

**Power source mode**

**A .first number is voltage: 2-220V, 3-380V**

**B.second number is the phase number: 1-single phase, 3-3 phases**

**Encoder type**

**1:2500p/r**

**2:500p/r**

**Connection mode**

**L : screw connector**

**C : tube base connector**

**Rated output power**

**Output power = number\*10(W)**

**Software version**

**General purpose version**

**Simplified version**

**Machine version**

**General purpose**

**Hosiery machine**

**Driver series number**

Output Power	Output Capacity (W)
003	30
075	750
150	1500

Software version Symbol	Version Note
A	Full function version
B	Simplified version

Encoder Type	Encoder Model
1	2500p/r
2	500p/r

※1: Simplified version has no RS485, CAN communication and D/A output compared with full function version.



1. 4 EPS1 series driver dimensions

- EPS1—040 servo motor driver dimension is shown in Fig. 1-1.

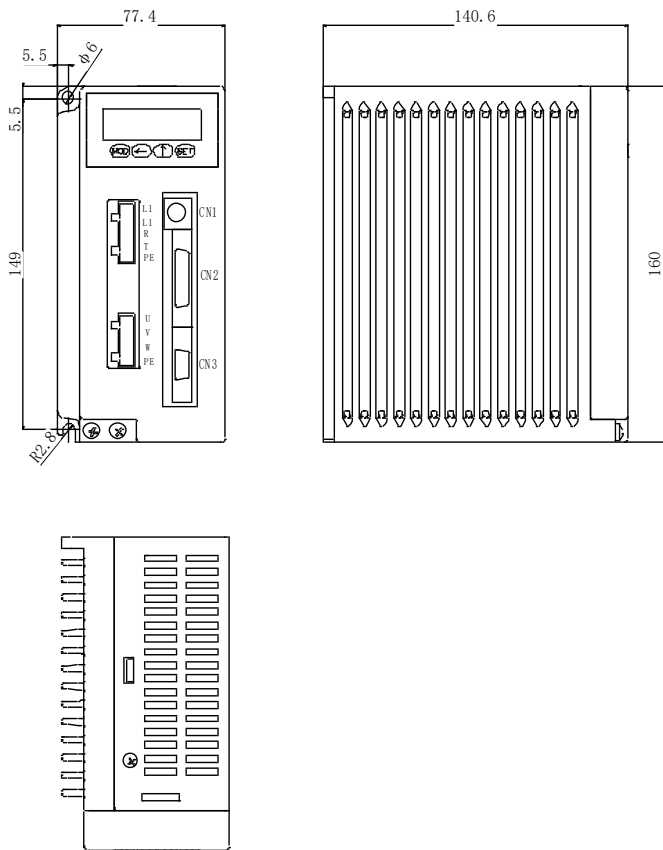

**Fig. 1-1** EPS1—040 servo motor driver dimensions (Unit: mm)

- EPS1-300 servo motor driver dimension is shown in Fig.1-2.

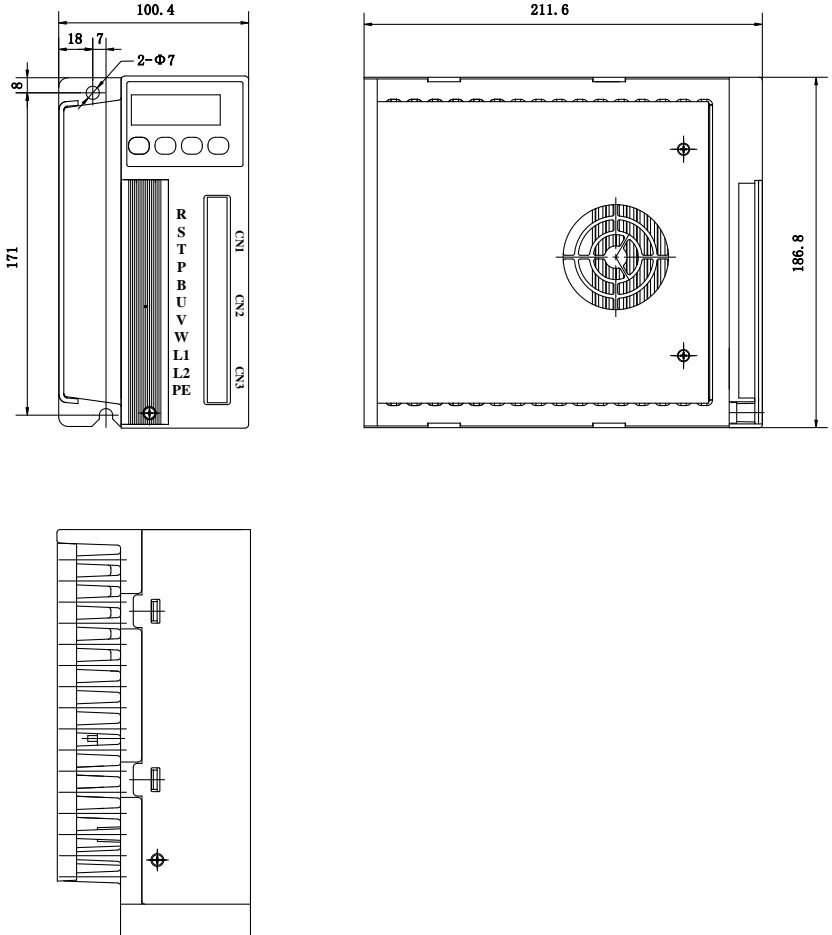

Fig. 1-2 EPS1—300 servo motor driver dimensions (Unit: mm)

- EPS1—500 servo motor driver dimension is shown in Fig.1-3.



图 1-3 EPS1—500 servo motor driver dimensions ( Unit: mm)

1. 5 EPS1 series driver compatible motor

The following table listed the configuration for the EPS1 series servo motor driver and servo motor

NO.02 Display	NO.01 Display	NO.09 Parameter	Power (KW)	Rated Speed (r/min)	Rated Torque (N.m)	Motor Model
310.100	-A 0	0	0.03	3000	0.0955	60DN1-M00130
	-A 1	1	0.05	3000	0.1590	60DN1-M00230
	-A 2	2	0.1	3000	0.3180	60DN1-M00330
	-A 3	3	0.2	3000	0.6370	60DN1-M00630
	-A 4	4	0.4	3000	1.2700	60DN1-M01330
	-A 5	5	0.6	3000	1.9100	60DN1-M01930
	-A 6	6	0.5	3000	1.5900	80DN1-M01630
	-A 7	7	0.75	3000	2.3900	80DN1-M02430
	-A 8	8	1	3000	3.1800	80DN1-M03230
	-A 9	9	0.75	3000	2.4000	90DN1-M02430
	-A 10	10	0.6	3000	2.0000	110DN1-M02030
	-A 11	11	1.2	3000	4.0000	110DN1-M04030
	-A 12	12	1.5	3000	5.0000	110DN1-M05030
	-A 13	13	1.2	2000	6.0000	110DN1-M06020
	-A 14	14	1.6	3000	6.0000	110DN1-M06030
	-A 15	15	1	2500	4.0000	130DN1-M04025
	-A 16	16	1.3	2500	5.0000	130DN1-M05025
	-A 17	17	1.5	2500	6.0000	130DN1-M06025
	-A 18	18	2	2500	7.7000	130DN1-M07725
	-A 19	19	1.5	1500	10.0000	130DN1-M10015
	-A 20	20	2.6	2500	10.0000	130DN1-M10025
-A 21	21	2.3	1500	15.0000	130DN1-M15015	

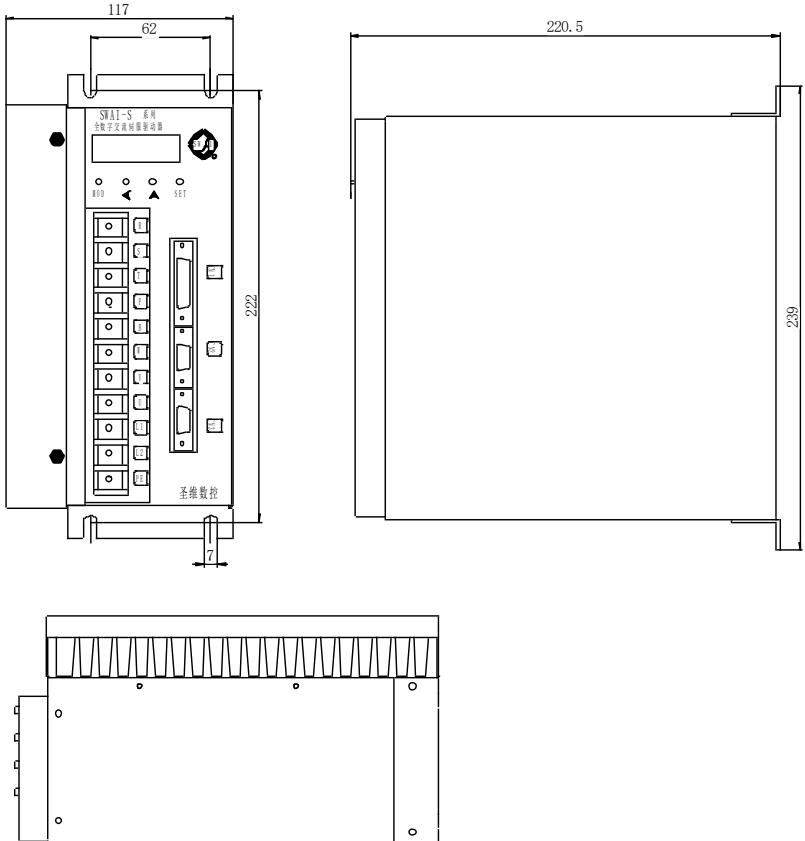
	-A 22	22	3.8	2500	15.0000	130DN1-M15025
--	-------	----	-----	------	---------	---------------

### 1.6 Parts Description

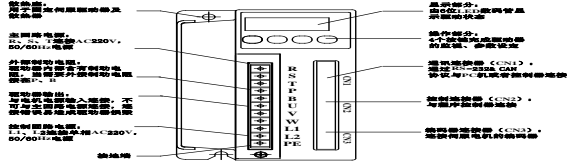

Fig.1-3 SC series driver illustration

左边从上到下:

Heat sink base:

For mounting the driver and heat sink

Main power input terminals:

R,S,T connected to AC 220V, 50/60Hz power source

External braking resistor:

Driver has its own braking resistor inside. An external braking resistor can be connected between P and B if required.

Driver output (Terminal for motor connection):

Connect to the motor. Never connect this to the main power supply which may damage the driver.

Control power input terminals:

L1,L2 connect to single phase AC 220V, 50/60 Hz power source.

右边从上到下:

Display part:

6 bit LED shows the driver status

Operation part:

4 buttons for monitoring and setting parameters

Communication connector ( CN1)

Connect to PC or controller via RS232 or CAN

Control connector (CN2)

Connect to program controller

Encoder connector(CN3)

Connect to servo motor encoder

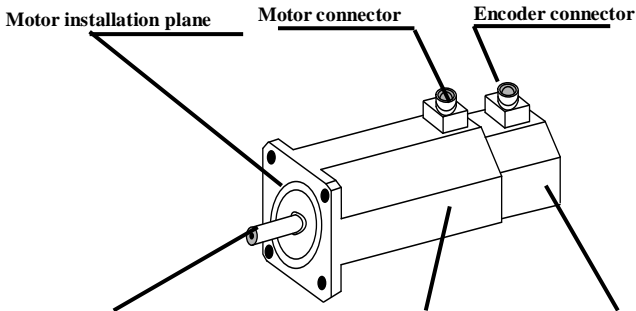

**Motor shaft**

**Motor cover**

**Encoder**

Fig.1-4 Servo motor outer view

## Chapter 2 Installation

### 2.1 Environmental Conditions

Servo motor driver required operation and storage environmental conditions are shown as in Table 2.1.

Table 2.1 Driver environmental conditions

Environment		Conditions
Ambient temperature	Operation	0°C~+55°C (free from freezing)
	Storage	-20°C~+65°C (free from freezing)
Ambient humidity	Operation	90%RH 以下 (free from condensation)
	Storage	
Air condition	Indoor ( No direct sun beams ) No corrosive and combustible atmosphere, no oil liquid, dust-free	
Altitude	Lower than 1000m	
Vibration	Less than 0.5G(4.9M/S <sup>2</sup> )	

### 2.2 Installation Place

#### 1) Installation in cabinet

The driver lifetime is highly related to the ambient conditions. When designing the electrical cabinet, all the components and instruments should be considered together for better allocation to meet the driver environmental and thermal condition requirements.

#### 2) Heat source around the driver

Operation at high temperature may reduce the driver lifetime and cause accident. Make sure the driver ambient temperature is lower than 55°considering thermal convection and thermal radiation.

#### 3) Vibrating instruments around the driver

Try to keep the driver away from the vibration source and keep the vibration below 0.5G(4.9M/S<sup>2</sup>).

#### 4) Driver operation under severe conditions

The driver may breakdown when it is opposed to the severe environments such

---

as corrosive gas, humidity, metal dust, water and processing liquids.

Some protection method must be used to guarantee the required working environment.

**5) Disturbance instruments around the driver**

EMI disturbance instruments around the driver may interfere with the power line and signal line, interrupting the driver normal operation. Noise filter and other anti-disturbance method can be used to keep normal operation. Adding filter may cause extra leakage current which can be avoided by adding isolation transformer to improve the power quality. Note that the control signal may easily be disturbed and proper wiring and shielding is needed.

**2.3 Mounting orientation and space**

**1) Mounting orientation**

The driver is supposed to be mounted vertically and kept proper height with the operation panel in front.

**2) Mounting method**

Use screws for mounting.

**3) Mounting space**

A certain space should be left between two drivers or between one driver and another instrument when mounting two or more drivers. The required space is: distance between two drivers should be larger than 25mm; distance between one driver and another instrument should be larger than 100mm. Please try to keep enough space to guarantee the driver lifetime and performance.

**4) Cooling**

If the driver is mounted inside the electrical cabinet, cooling fans installation is suggested to provide vertical air flow for cooling the heat sink.

**5) Prevent other objects falling into the driver during mounting**

Try to avoid drilling metal dust or cutting pieces falling into the driver when installing the control cabinet. Inspect whether oil, water or metal dust can go inside the driver though the gap or fans. If that happens, please use some protection



method to ensure the required environment.

2.4 Motor installation

- 1) Don't submerge the motor cable to oil or water.

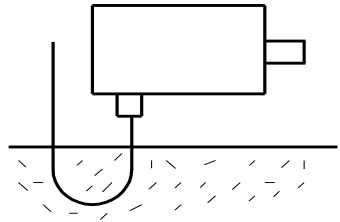

- 2) Do not apply direct impact to the shaft or encoder while attaching/detaching a coupling to and from the motor shaft, otherwise, the encoder may be damaged. Please align the shaft to the best position.

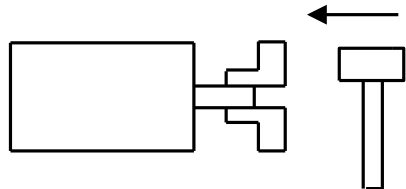

- 3) Do not let oil, water or metal dust into the motor connector. Certain protection method should be adopted. Otherwise, the driver may not work properly and the encoder or motor can be damaged permanently.

2.5 Servo motor driver installation figures

<1> Installation for single driver:

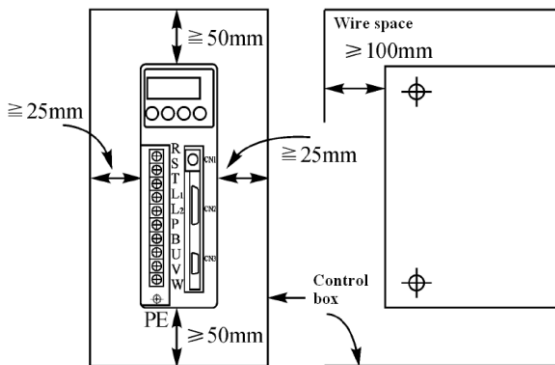

Fig. 2-1 Installation for single driver



## Chapter 3 Wiring

### 【CAUTION】

- Please shut off the power before wiring or inspection. As there are lots of electrolytic capacitors inside the driver which will maintain certain high voltage even if the power is shut off. After shutting off the power, wait at least 10 minutes for the charging indicator LED turning off, then start to wire or inspect the driver or motor to avoid the electrical shock.
- Driver output terminal U,V,W must be connected to the corresponding motor terminal U,V,W correctly. Don't try to change the sequence of the 3-phase terminal to reverse the motor rotation direction and do not short the terminals. Phase sequence fault may cause motor start-up failure, abnormal operation or other unexpected conditions.
- Make sure the connection between the encoder (on the motor shaft) and driver is correct. In order to avoid disturbance, power line and encoder signal line should be wired separately. Shielding wire is suggested for the encoder signal line.

### 3.1 Driver configuration and connection to peripheral device

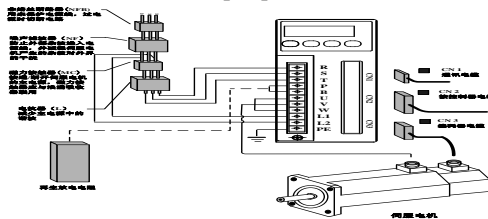

Fig. 3-1 Driver connection to peripheral device

从上至下，左边：

Non-fusible breaker (NFB)：

Protect the power line; break down the circuit during over-current

Noise Filter (NF)

Prevent external noise from going into the power line and reduce the driver disturbance to peripheral device.

Magnetic Contactor (MC)

Connect/disconnect the power from the motor. It should be used together with inrush current absorbing circuit.

Reactor (L)

Reduce the harmonics in the power line

Regenerative resistor (braking resistor)

从上至下，右边：

Communication cable (CN1)

Control cable (CN2)

Encoder cable (CN3)

Servo motor

---

## 3.2 Standard connection

### 1. Wire requirement

#### (1) Power terminal TB

- Wire size: R, S, T, U, V, W, PE terminal wire size  $\geq 1.5\text{mm}^2$  (AWG14-16), L1, L2 terminal wire size  $\geq 1.0\text{mm}^2$  (AWG16-18). Large power driver needs bigger TB terminal wire size.
- Grounding: Grounding wire (PE) size should be as large as possible. Driver grounding wire and servo motor grounding wire should be connected to ground at a single point and the grounding resistance should be less than  $100\Omega$ .
- Terminal connection should be firm and reliable.
- 3-phase isolation transformer is suggested to use to improve power quality and anti-noise ability.
- Please install non-fusible breaker (NFB) to shut off the power during driver fault.
- Noise filter (NF), Magnetic contactor (MC) and Reactor (L) are suggested to add for filtering noise and improve EMI.

#### (2) Communication signal CN1, Control signal CN2, Encoder signal CN3

- Wire size: Suggest using shielding wire (better to use twisted-pair shielding wire). Wire size  $\geq 0.12\text{mm}^2$  (AWG24-26).
- Wire length: Wire length should be as short as possible. Control signal wire CN2 can not exceed 5 meters. Encoder signal wire should be less than 15m. Encoder power wire and grounding wire should use at least 4 set of wires in parallel connection respectively.
- Wiring: Keep away from power line to reduce noise.
- Please add inrush current absorber circuit for inductive components (e.g. coil): Dc-coil needs anti-parallel diode and ac-coil needs parallel RC absorber circuit.

#### (3) Note

- Power line and signal line should be firm and reliable, kept away from the driver heat sink and motor to avoid heat-caused insulation problem.
- All circuits must be connected correctly before powering on.

## 2. Typical Wiring

### 1) Position control mode

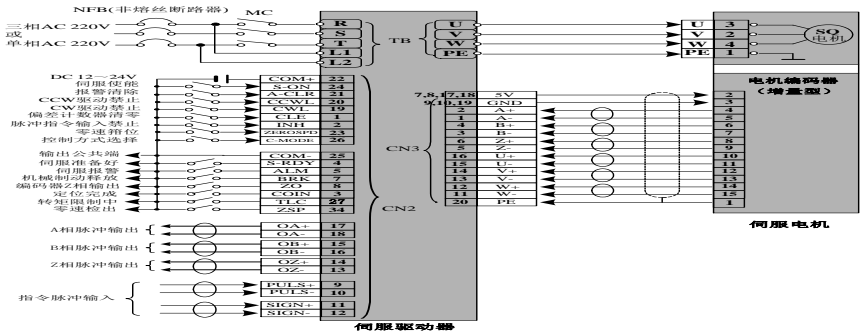

Fig. 3-2 Position control mode wire connection

从上至下，左边：

NFB (non-fusible breaker)

3-phase AC 220V

or single phase AC 220V

DC 12-14V

Servo enable

Alarm clear

CCW drive disable

CW drive disable

Error counter clear zero

Pulse command input disable

Zero-speed clamp

Control mode selection

Output common terminal

Servo ready

Servo alarm

Mechanical brake release

Encoder z-phase output

Positioning complete

Torque limiting

Zero-speed detection

Phase A pulse output

Phase B pulse output

Phase Z pulse output

Command pulse input

中间：

Servo motor driver

右边：

motor

Motor encoder (incremental)

Servo motor

### 2) Speed/Torque control mode

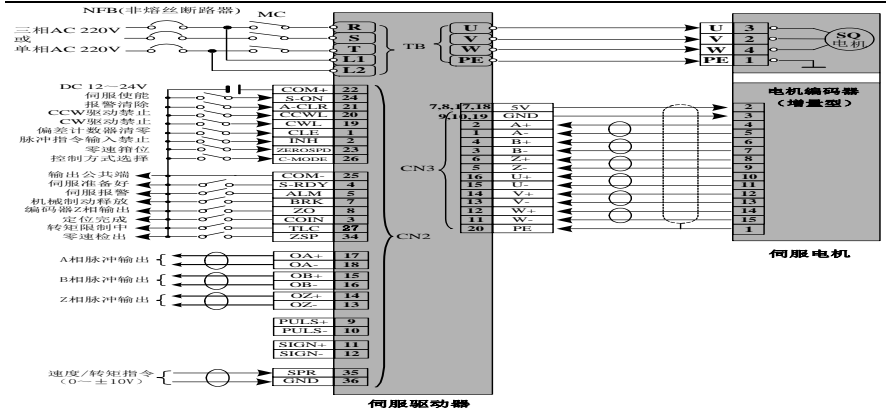

Fig. 3-3 Speed/Torque control mode wire connection

从上至下，左边：

- NFB (non-fusible breaker)
- 3-phase AC 220V
- or single phase AC 220V
- DC 12~14V
- Servo enable
- Alarm clear
- CW drive disable
- CW drive disable
- Error counter clear zero
- Pulse command input disable
- Zero-speed clamp
- Control mode selection
- Output common terminal
- Servo ready
- Servo alarm
- Mechanical break release
- Encoder z-phase output
- Positioning complete
- Torque limiting
- Zero-speed detection
- Phase A pulse output
- Phase B pulse output
- Phase Z pulse output
- Speed/Torque command (0~+10V)

中间：

Servo motor driver

右边：

motor

Motor encoder (incremental)

Servo motor

### 3.3 Terminal functions

1. Power terminal TB

Table 3.1.1 EPS□□-040 driver power terminal

Symbol	Signal Name	Function
<b>R</b>	Main circuit power	Main circuit power input terminal AC 220V, 50Hz / 60Hz
<b>TBT-2</b>		
<b>L1</b>	Control Circuit Power	Control circuit power input terminal AC220V, 50 / 60Hz
<b>L2</b>		
<b>U</b>	Connection to servo motor	These terminals should be connected to compatible servo motor and terminals U,V,W should match between driver and motor. (See Chap. 7.1) .
<b>V</b>		
<b>W</b>		
<b>PE</b>	System ground	Grounding terminal; Grounding resistance<100Ω; Servo motor and power input should be grounded at single point.

Table 3.1.2 EPS EPS□□-150— EPS□□-500 driver power terminal TB

Symbol	Signal name	Function
<b>R</b>	Main circuit power (single phase or 3-phase)	Main circuit power input terminal AC220V, 50 / 60Hz
<b>S</b>		
<b>T</b>		
<b>L1</b>	Control circuit power (single phase)	Control circuit power input terminal AC 220V, 50Hz / 60Hz
<b>L2</b>		
<b>P</b>	External braking resistor connection	When driver output power is large and the internal braking resistor is not enough for burning the excessive energy, an external braking resistor can be added between terminal P and B.
<b>B</b>		
<b>U</b>	Connect to servo motor	Driver output terminals must match the motor terminals U, V, W respectively(see Chap. 7.1) .
<b>V</b>		
<b>W</b>		
<b>PE</b>	System ground	Grounding terminal; grounding resistance<100Ω; servo motor output and power input should be grounded at a single point.

2. Communication terminal CN1

CN1 is communication connector for parameter read and set through RS232 and RS485.

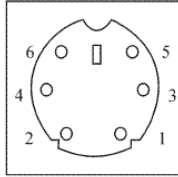

EPS driver communication terminal

Table 3.2 Communication Terminal CN1

Input terminal	Signal name	symbol	function	I / O type
CN1-6	communication power supply	VCC	+5V	-
CN1-5		GND	GND	-
CN1-4	RS232 communication	R1IN	Signal receiving, connect to RS 232 transmission port of PC	-
CN1-2		T1OUT	Signal transmission, connect to RS 232 receiving port of PC	
CN1-1	RS485 communication	TxOUT/RxI N+	Signal transmission differential signal +	Type 3
CN1-3		TxOUT/RxI N-	Signal transmission differential signal -	

### 3. Control Terminal CN2



CN2 socket is male (needle) and plug is female. It is for communication with upper-level controller.

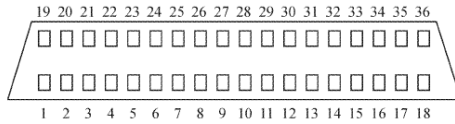

EPS1 driver control signal terminal

Table 3.3 Control terminal CN2 functions

Pin number	Signal name	symbol	function	I / O type
CN2-31	Analog torque reference input	T-Ref	Analog torque reference input terminal; Range: 0~±10V DC.	--
CN2-33	Analog speed reference input	S-Ref	Analog speed reference input terminal; Range: 0~±10V DC.	--
CN2-35,36	Analog ground	GNDA	Analog control signal input ground	--
CN2-17	Phase-A output	OA+	Provide encoder differential signal output from long distance driver (Phase A, B and Z) non-isolated. Parameter No. 25 can be used to change phase A and B output frequency divider coefficient. Parameter No.26 can be set to change the logic relationship between phase A and B.	type5
CN2-18		OA-		
CN2-15	Phase B output	OB+		
CN2-16		OB-		
CN2-14	Phase Z output	OZ+		
CN2-13		OZ-		
CN2-22	Control power supply (+)	COM+		
CN2-1	Counter clear zero	CLE	For position control, this bit (low effective) is used to clear the position error zero.	Type 1

CN2-21	Alarm clear	A-CLR	Alarm clear terminal(low effective) A-CLR effective: clear system alarm. A-CLR ineffective: hold system alarm	Typel		
CN2-26	Control mode selection	C-MODE	When NO. 04 【control mode selection】 =3, 4 or 5, control modes are shown in the following table:	Typel		
			NO. 4		Disconnect to COM-	Connect to COM-
			3		Position control mode	Speed control mode
			4		Position control mode	Torque control mode
5	Speed control mode	Torque control mode				
CN2-20	CCW Drive disable	CCWL	When CCWL/CWL is effective, motor stops at CCW/CW direction, keeps zero speed and maintains output torque. When receiving CW/CCW direction from upper level-controller control signal, it starts to run normally.	Typel		
CN2-19	CW Drive disable	CWL	<ul style="list-style-type: none"> <li>◇ Used for mechanical position limit switch; when the signal is low, motor stops by default setting.</li> <li>◇ Parameter No.64 is used to set the logic level.</li> <li>◇ NO.06 【 Drive disable input ineffective】 is used to shield this signal.</li> </ul>	Typel		
CN2-24	Servo enable	S-ON	<p>effective : enable driver(low effective) ineffective: disable driver; output turns off; driver stop running; motor idle.</p> <ul style="list-style-type: none"> <li>◇ When S-ON is effective, wait at least 50ms , then start to enter the command.</li> <li>◇ Don't use S-ON to start and stop the motor frequently..</li> </ul>	Typel		
CN2-23	Zero-speed clamp	ZEROSPD	Disconnect with COM-; speed reference is taken as zero. Parameter NO. 08 【zero speed input selection】 can be used to disable this signal.	typel		

CN2-2	Command input pulse disable	INH	When INH is effective (low effective), command pulse input is disabled. Parameter NO.29 【command pulse input disable】 can be used to disable this signal.	Type1
CN2-25	Control power supply (—)	COM-	Output terminal optical-coupler common point.	--
CN2-7	Mechanical brake release	BRK_OFF	When mechanical brake release, this output (transistor) conduct.	Type2
CN2-4	Servo ready	S-RDY	S-RDY effective: Control power and main power condition is normal. No driver alarm, servo output ready S-RDY ineffective: driver alarm, servo output not ready(high)	Type2
CN2-5	Servo Alarm	ALM	ALM alarm: When driver detects fault, it outputs alarm signal (high). ALM no-alarm: When driver has no faults, no alarm signal output. (low)。	Type2
CN2-8	Phase-Zo utput	ZO	Servo motor encoder Phase-Z pulse output, open collector (OC) output.	Type2
CN2-3	Positioning Complete	COIN	When positioning is complete, this output (transistor) conducts.	Type2
CN2-27	Torque limiting	TLC	Output conducts when torque is limiting.	Type2
CN2-34	Zero-speed detection	ZSP	When motor speed is below NO.51(zero speed)setting value, this output conducts.	Type2
CN2-9	Command pulse input	PULS+	Command pulse input terminal. Command pulse can be input in three different forms. Use No.28 to choose one of the following forms. 1、Quadruple (A&B) input. 2、CW/CCW pulse input. 3、Command pulse/direction input.	Type3
CN2-10		PULS-		
CN2-11	Command pulse direction input	SIGN+		
CN2-12		SIGN-		

4. Encoder signal terminal CN3

CN3 socket is female and plug is male (needle), which is used to connect the encoder. Twisted-pair shielding wire is suggested. When the length exceeds 10 meters, power and grounding cable is better to use multi-core wires and the wire size should be bigger than 0.15mm<sup>2</sup>.

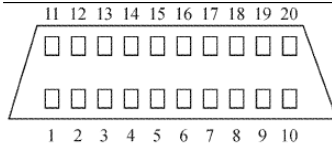

EPS1 driver encoder signal terminal

Table 3.4 Encoder signal terminal CN3

Terminal number	Signal name	Symbol	Function	I / O
CN3-7 CN3-8 CN3-17 CN3-18	Encoder power supply	VCC	Servo motor encoder uses +5V power supply and the wire size should increase when the cable length exceeds 10m.	---
CN3-9 CN3-10 CN3-19		GND		---
CN3-20	Shielding ground	PE	Motor, driver and cabinet ground should connect together with the encoder ground.	---
CN3-2	Encoder A+ input	A+	Connect to servo motor encoder phase-A	Type4
CN3-1	Encoder A- input	A-		
CN3-4	Encoder B+ Input	B+	Connect to servo motor encoder phase-B	
CN3-3	Encoder B- Input	B-		
CN3-6	Encoder Z+ Input	Z+	Connect to servo motor encoder phase-Z	
CN3-5	Encoder Z- Input	Z-		
CN3-16	Encoder U+ Input	U+	Connect to servo motor encoder phase-U	
CN3-15	Encoder U- Input	U-		
CN3-14	Encoder V+ Input	V+	Connect to servo motor encoder phase-V	
CN3-13	Encoder V- Input	V-		
CN3-12	Encoder W+ Input	W+	Connect to servo motor encoder phase-W	
CN3-11	Encoder W- Input	W-		

3.4 I/O interface

1. Switch signal input interface

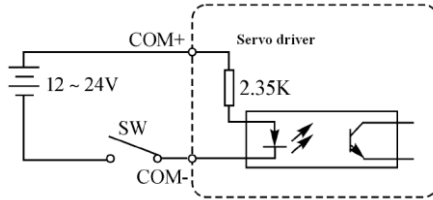

Fig. 3-4 Type 1 switch signal input interface

- (1) External power source is provided by user. Please note if the power polarity is misconnected, the driver may damage.
- (2) Power supply requirement: DC 12~24V (Recommend: DC 24V), current $\geq$ 100mA.

2. Switch signal output interface

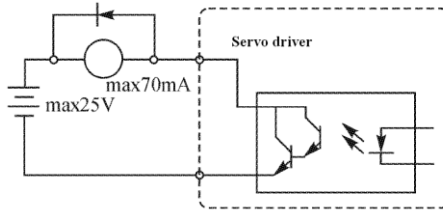

Fig. 3-5 Type 2 switch signal output interface

- (1) External power source is provided by user. Please note if the power polarity is misconnected, the driver may damage.
- (2) Open-collector (OC) output, the maximum current is 70mA and maximum external power source voltage is 25V. If the rated value is exceeded or the output is directly connected to power source, the driver may damage.
- (3) If the load is relay or other inductive load, an anti-parallel diode is needed for current free-wheeling. If the diode polarity is misconnected, the driver may damage.

3. Pulse signal input interface

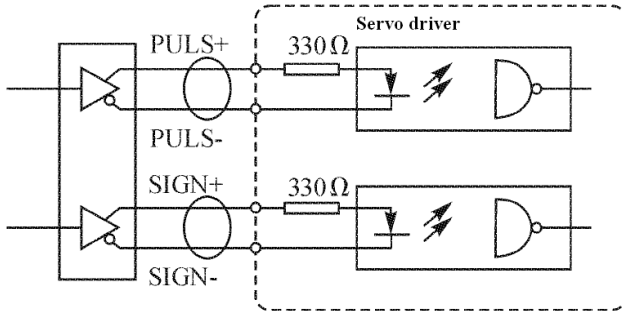

Fig.3-6 Type 3 pulse signal input interface in differential drive mode

- 1) For differential signal drive, RS422 driver, e.g. AM26LS31 is suggested.
- 2) In order to improve the pulse data anti-noise ability, the differential drive mode is suggested.

4. Driver optical encoder input interface

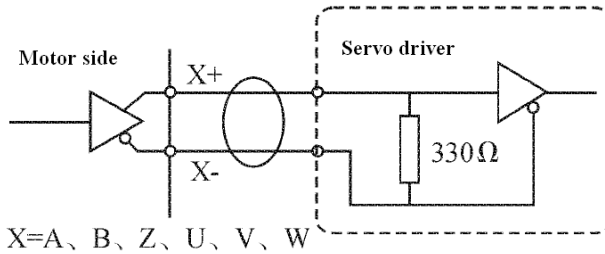

Fig. 3-7 Type 4 servo driver optical encoder input interface  
Receiving encoder output A, B, Z, U, V, W signal.

5. Long-wire driver(differential output) interface

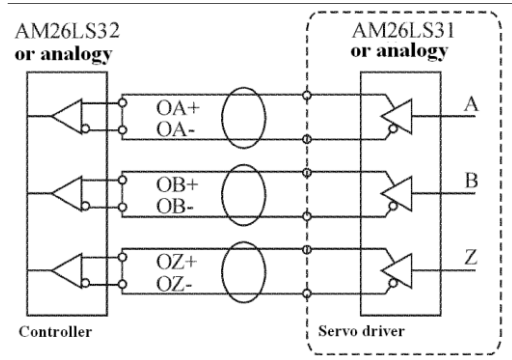

Fig. 3-8 Type 5 long-wire driver output interface

- (1) Long-wire driver output signal is non-isolated
- (2) For long-wire signal receiver, in this case, a 330Ω resistor is connected at the input.

**[NOTE]**

- ◆ **Driver and motor must be grounded reliably.** Driver power feeds the motor through power transistors. Improper wiring or grounding may introduce noise to the system. For this, firmly grounding is required.
- ◆ **To avoid electrical shock, driver protection ground (PE) terminal must be connected to cabinet protection ground (PE).**
- ◆ **Symbol () in this manual represents twisted-pair wires.**

3.5 Power supply circuit

The following graph depicts the driver wire connection with 3-phase and single phase power supply.

- (1) 3-phase AC 220V power input

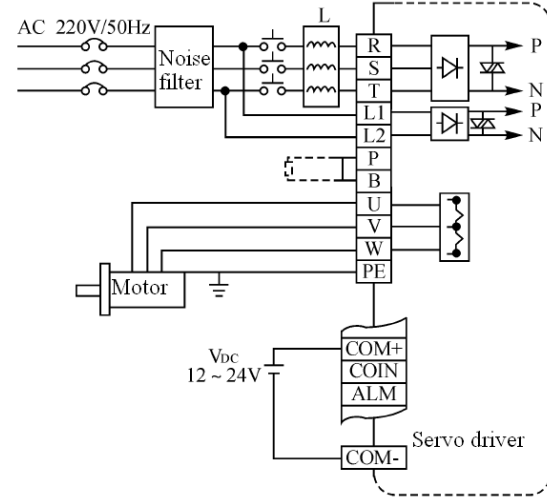

Fig. 3-9 3-phase 220V driver wire connection

(2) Single phase AC 220V power input

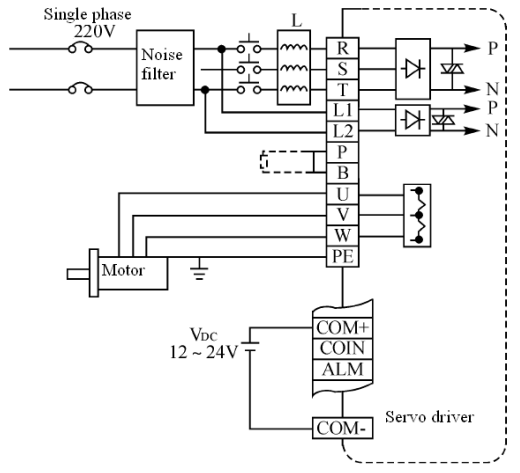

Fig. 3-10 single phase 220V servo driver wire connection



## Chap. 4 Parameters

### 【CAUTION】

- Inappropriate parameter setting may cause the system unstable. Please be careful with it.
- Forward rotation means motor rotation is counter-clockwise seen from the motor shaft direction. Reverse rotation means motor rotation is clockwise seen from the motor shaft direction.
- Parameters with “※” can be modified and displayed, but is not effective in the control until written into EEPROM and then re-power on. Other parameters value can be changed and become effective in the control immediately after change.
- Parameters with “★” are read-only parameters, writing is invalid.
- Parameters with “▲” are under development for future function extension.

### 4.1 Parameter overview

Table 4.1 User parameters (Password: 58)

	No.	Parameter name	Set range	Default range
Function Selection	00	Driver password	0~9999	58
	01★	Driver version display	---	---
	02★	Software version	---	---
	03※	LED initial display status	0~30	0
	04※	Control mode selection	0~8	0
	05	Torque limit input disable	0~1	0
	06	Driver disable input	0~1	1
	07	Zero-speed input signal	0~1	1
	08	Zero-speed input selection	0~1	0
	09※	Driver version selection	0~50	15
	10▲	Analog output channel	0~8	0
Gain and	11	Position loop gain	500~8000	2200
	12	Position feed-forward gain	0~100	0

filter parameters	13	Position feed-forward	0~1024	2
	14	Speed loop gain	500~8000	3000
	15	Speed loop integral time	500~6000	2000
	16	Speed sampling filtering	0~4096	25
	17	reserved	--	--
	18▲	Speed loop differential	0~100	0
	19	reserved	--	--
	20	S function enable	0~1	1
	21	S function constant	1~16	1
	23~	reserved	--	--
Position control parameters	25※	Motor encoder feedback	1~255	1
	26※	Output pulse logic reverse	0~1	0
	27※	Input pulse logic reverse	0~1	0
	28	Command pulse input mode	0~2	0
	29	Command pulse disable input	0~1	1
	30	reserved	--	--
	31	Electrical gear numerator	1~9999	1
	32	Electrical gear	1~9999	1
	33~	reserved	--	--
	37	Internal position register	1~16	16
38	reserved	--	--	
Speed, torque control parameters	39	Acceleration time constant	10~3000	200
	40	Deceleration time constant	10~3000	200
	41~	reserved	--	--
	43	Speed reference input gain	10~1000	200
	44	Speed reference input logic	0~1	0
	45	Speed reference zero-drift	-2048~2048	0
	46	Torque reference input gain	1~100	10
	47	Torque reference input	0~1	0
	48	Torque limit setting	0~300	200
49	reserve	--	--	
Logic program	50	Positioning complete range	1~9999	50
	51	Zero speed	0~2000	50

related parameters	52	Speed arrival	0~3000	2000
	53	Position error exceed	1~9999	500
	54	Position error abnormal	0~1	0
	55~	reserved	--	--
	58	Mechanical brake action	1~1000	10
	59	reserved	--	--
	60	Mechanical brake action	0~1000	10
	61	Motor speed when mechanical	0~200	50
	62~	reserved	--	--
	64	Input signal logic	0~255	0
	65	reserved	--	--
	66	Input terminal logic selection	0~255	2
	67~	reserved	--	--
	Communication Related parameters	69✕	Communication method	0~2
70▲		Software input connection point, communication	0~1024	0
71		reserved	--	--
72✕		232、485 communication driver number setting	0~255	0
73✕		232、485 communication speed-rate setting	0~6	0
74✕		232、485 communication protocol selection	0~8	6
75~		reserved	--	--
Internal position control parameters	83	Internal position command 1 speed setting	-9999~9999	1
	84	Internal position command 1 pulse number setting	-9999~9999	1
	85	...2...	-9999~9999	1
	86	...2...	-9999~9999	1
	87	...3...	-9999~9999	1
	88	...3...	-9999~9999	1

89	...	-9999~9999	1
90		-9999~9999	1
91		-9999~9999	1
92		-9999~9999	1
93		-9999~9999	1
94		-9999~9999	1
95		-9999~9999	1
96		-9999~9999	1
97		-9999~9999	1
98		-9999~9999	1
99		-9999~9999	1
100		-9999~9999	1
101		-9999~9999	1
102		-9999~9999	1
103		-9999~9999	1
104		-9999~9999	1
105		-9999~9999	1
106		-9999~9999	1
107		-9999~9999	1
108		-9999~9999	1
109		-9999~9999	1
110		-9999~9999	1
111		-9999~9999	1
112		-9999~9999	1
113		-9999~9999	1
114		-9999~9999	1
115	Internal position command 1 moving speed	0~3000	100
116	...2...	0~3000	100
117	...	0~3000	100
118		0~3000	100

	119		0~3000	100
	120		0~3000	100
	121		0~3000	100
	122		0~3000	100
	123		0~3000	100
	124		0~3000	100
	125		0~3000	100
	126		0~3000	100
	127		0~3000	100
	128		0~3000	100
	129		0~3000	100
	130		0~3000	100
Internal speed control parameters	131	Internal speed command 1	-3000~3000	500
	132	...2	-3000~3000	500
	133	...	-3000~3000	500
	134		-3000~3000	500
Internal torque control parameters	135	Internal torque command 1	-300~300	50
	136	...2	-300~300	50
	137	...	-300~300	50
	138		-300~300	50
Internal position control delay parameters	139	Delay register 1	0~9999	100
	140	...2	0~9999	100
	141	...	0~9999	100
	142		0~9999	100
	143		0~9999	100
	144		0~9999	100
	145		0~9999	100
	146		0~9999	100
	147		0~9999	100
	148		0~9999	100
	149		0~9999	100
	150		0~9999	100
	151		0~9999	100

	152		0~9999	100
	153		0~9999	100
	154		0~9999	100
	155	reserved	--	--

4.2 Parameter function

Table 4.2 Parameter function (Password: 58)

Number	Parameter name	Function	Default range 【default value】
00	Password	Prevent parameters from being changed by mistake. Before changing other parameters, this parameter must be set to 58 first. After setting other parameters, change this parameter to be other values except 58 to avoid other parameters changed by mistake.	0~9999 【 58 】
01 ★	Driver version display	1. This parameter is for checking only and can not be modified. 2. By changing parameter NO.09【Driver version selection】, driver version will change accordingly. 3. Please use the compatible driver and motor.	-- --
02 ★	Software version	This parameter is for checking software version only, can not be modified.	-- --

<p>03 ※</p>	<p>Initial display status</p>	<p>Selection for the initial LED display content after powering on.                      0: Display motor speed;                      1: Display motor feedback pulse lower 4 bits;                      2: Display motor feedback pulse higher 4 bits;                      3: Display position receiving command lower 4 bits;                      4: Display position receiving command higher 4 bits;                      5: Display position error;                      6: Display encoder resolution;                      7: Display speed reference input value;                      9 : Display torque reference input value percentage[%];                      13: Display motor average current;                      15: Display pulse input frequency;                      16: Display main circuit voltage;                      17: Display rotor position in a circle;                      18: Display input terminal status;                      19: Display output terminal status;                      20: Display encoder status;                      21: Display control mode;                      22: Display operation status;                      23: Display Id;                      24: Display Iq;                      25: Display alarm record 1;                      26: Display alarm record 2;</p>	<p>0~35</p>			
<p>03 ※</p>	<p>Initial display status</p>	<p>27: Display alarm record 3;                      28: Display alarm record 4;                      08, 10, 12, 14, 29~35 are reserved;</p>	<p>0~35 【 0 】</p>			
<p>04 ※</p>	<p>Control mode selection</p>	<p>Select driver control mode</p> <table border="1" data-bbox="288 1295 868 1359"> <tr> <td data-bbox="288 1295 408 1359">Setting Value</td> <td data-bbox="408 1295 674 1359">Mode I</td> <td data-bbox="674 1295 868 1359">Mode II</td> </tr> </table>	Setting Value	Mode I	Mode II	<p>0~8 【 0 】</p>
Setting Value	Mode I	Mode II				

		0	Position control mode	—	
		1	Speed control mode	—	
		2	Torque control mode	—	
		3	Position mode	Speed mode	
		4	Position mode	Torque mode	
		5	Speed mode	Torque mode	
		6	Internal position control mode	—	
		7	Internal speed control mode	—	
		8	Internal torque control mode	—	
		CN2-26 (C-MODE) is used to switch between Mode I and Mode II;			
05	Torque limit input disable	To disable analog torque limit signal input (counter-clockwise or clockwise). 1: input ineffective; Response to torque input signal normally; 0: input effective. Mask off the torque input signal.		0~1 【 1 】	























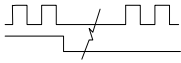

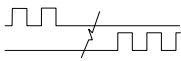

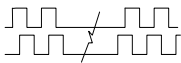

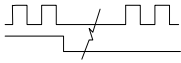

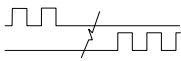

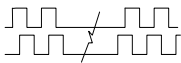
06	Drive r disab le input ineff ectiv e	Va lu e	In pu t	Control input	Connect to COM-	Operation	0~1 【 1 】
		0	ef fe ct iv e	CCWL (CN2-20)	Connect ed (L)	Normal , CCW limit switch no action	
					Open (H)	CCW direction operation is prohibited, CW direction is allowed	
			CWL (CN2-19)	Connect ed (L)	Normal , CW limit switch no action		
				Open (H)	CW direction operation is prohibited, CCW direction is allowed.		
1	in ef fe ct iv e	CCWL and CWL input are both ineffective, clockwise and counter-clockwise operation are both allowed.					
<p>If this parameter is set to zero, and CWL/CCWL are both open circuit (not connect to COM-), driver will have alarm 23 【driver disable abnormal】.</p>							

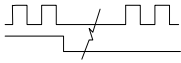
07	<p>Zero-speed input function selection</p> <hr/> <p>Zero-speed signal effectiveness selection</p>	<p>In speed control mode, ZEROSPD signal (Pin CN2-23) function selection.</p> <table border="1" data-bbox="304 197 844 394"> <thead> <tr> <th>value</th> <th>ZEROSPD signal function</th> </tr> </thead> <tbody> <tr> <td>0</td> <td>When ZEROSPD signal is effective, motor speed is clamped to be zero.</td> </tr> <tr> <td>1</td> <td>When ZEROSPD signal is effective, motor speed reference is zero.</td> </tr> </tbody> </table>	value	ZEROSPD signal function	0	When ZEROSPD signal is effective, motor speed is clamped to be zero.	1	When ZEROSPD signal is effective, motor speed reference is zero.	<p>0~1 【 1 】</p>
value	ZEROSPD signal function								
0	When ZEROSPD signal is effective, motor speed is clamped to be zero.								
1	When ZEROSPD signal is effective, motor speed reference is zero.								
08		<p>Enable and disable zero-speed clamp ZEROSPD signal (Pin CN2-23) Switch between enable and disable, this parameter is valid for speed control mode.</p> <table border="1" data-bbox="304 797 844 933"> <thead> <tr> <th>Value</th> <th>ZEROSPD signal effective and ineffective selection</th> </tr> </thead> <tbody> <tr> <td>0</td> <td>ZEROSPD input disable</td> </tr> <tr> <td>1</td> <td>ZEROSPD input enable</td> </tr> </tbody> </table>	Value	ZEROSPD signal effective and ineffective selection	0	ZEROSPD input disable	1	ZEROSPD input enable	<p>0~1 【 0 】</p>
Value	ZEROSPD signal effective and ineffective selection								
0	ZEROSPD input disable								
1	ZEROSPD input enable								
09 ※	<p>Driver version selection</p>	<ul style="list-style-type: none"> <li>• According to “1.5 SC series driver compatible motor”, set proper driver version number to this parameter.</li> <li>• Make sure to choose the compatible driver for the motor, otherwise, unexpected condition may happen.</li> </ul>	<p>0~50 【 15 】</p>						

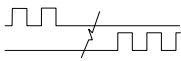
<p>10 ▲</p>	<p>Analog output channel selection</p>	<p>Analog output monitoring:                      0: Motor speed (0~5V, 5V for the maximum speed)                      1: Motor torque (0~5V, 5V for the maximum torque)                      2: Motor current (0~5V, 5V for the maximum current)                      3: input pulse frequency (0~5V corresponding to 0~500K)                      4: Speed command (0~5V corresponding to -10V~+10V)                      5: Torque command (0~5V corresponding to -10V~+10V )                      6: Main circuit voltage (0~5V corresponding to 0~500V)</p>	<p>0~8 【 0 】</p>
<p>11</p>	<p>Position loop gain</p>	<p>Set the position loop controller proportional gain to define the position control response curve.</p> <ul style="list-style-type: none"> <li>• Larger setting value means higher gain, higher stiffness, less delay, faster positioning for the same frequency pulse command.</li> <li>• Too large value for this parameter may cause system unstable, oscillation or overshoot.</li> </ul>	<p>500~8000 【 2200 】</p>
<p>12</p>	<p>Speed feed-forward</p>	<ul style="list-style-type: none"> <li>• This parameter can be set to change the speed feed-forward term in the position control(%). Larger setting value means faster and better position loop response and position tracking.</li> <li>• Too large value for this parameter may cause system unstable, oscillation or overshoot.</li> </ul>	<p>0~100 【 0 】</p>
<p>13</p>	<p>Feed-forward time constant</p>	<ul style="list-style-type: none"> <li>• This parameter can be used to set the time constant of the filter for the speed feed-forward term.</li> <li>• This function help to reduce the speed overshoot or detuning.</li> </ul>	<p>0~1024 【 2 】</p>
<p>14</p>	<p>Speed loop gain</p>	<ul style="list-style-type: none"> <li>• Setting the speed loop controller proportional gain.</li> <li>• Larger setting value means higher loop gain, higher stiffness. Usually, the bigger the load inertia is, the larger value should be set.</li> <li>• The gain is suggested to be set higher, as long as there is no system oscillation.</li> </ul>	<p>500~8000 【 3000 】</p>

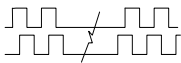
15	Speed loop integral time constant	<ul style="list-style-type: none"> <li>• The smaller the setting value is, the faster the integration is, and the higher the stiffness is.</li> <li>• Usually, the bigger the load inertia is, the bigger the setting value should be.</li> <li>• The value is suggested to be set smaller, as long as there is no system oscillation.</li> </ul>	500~6000 【 2000 】
16	Speed Detection filter	<ul style="list-style-type: none"> <li>• When the motor speed error is large, properly increasing the value of this parameter can get better performance.</li> <li>• If the load inertia is large, the value can be increased.</li> <li>• Too large value will slow down the response and may cause oscillation.</li> </ul>	0~8100 【 0 】
17	Speed command filter	<ul style="list-style-type: none"> <li>• The bigger the setting value is, and the smoother the speed command is.</li> <li>• Too large value will slow down the response.</li> </ul>	0~8100 【 0 】
18 ▲	Speed loop differential gain	<ul style="list-style-type: none"> <li>• Speed loop differential gain parameter.</li> </ul>	0~100 【 0 】
25 ※	Encoder output frequency division ratio	<ul style="list-style-type: none"> <li>• This parameter is used to set the encoder output pulse frequency division ratio. For example, if the encoder is 2500-line resolution, and this parameter is set to be 5, the A/B signal output is 500 lines.</li> </ul>	1~255 【 1 】

<p>26 ※</p>	<p>Pulse output logic reverse</p>	<p>When the motor is rotating clockwise, phase-B pulse is leading phase-A pulse. (When the motor is rotating counter-clockwise, phase-B pulse is lagging phase-A pulse). This parameter can be used to reverse the logic of phase-B pulse, thus changing the phase relationship between A and B.</p> <table border="1" data-bbox="304 329 802 545"> <thead> <tr> <th>Value</th> <th>Phase A</th> <th>CCW rotation</th> <th>CW rotation</th> </tr> </thead> <tbody> <tr> <td>0</td> <td>Phase B not reverse</td> <td></td> <td></td> </tr> <tr> <td>1</td> <td>Phase B reverse</td> <td></td> <td></td> </tr> </tbody> </table>	Value	Phase A	CCW rotation	CW rotation	0	Phase B not reverse			1	Phase B reverse			<p>0~1 【 0 】</p>								
Value	Phase A	CCW rotation	CW rotation																				
0	Phase B not reverse																						
1	Phase B reverse																						
<p>27 ※</p>	<p>Pulse input logic reverse</p>	<p>When you want to change the motor rotation direction, but do not want to change the polarity of the command signal from the controller, this parameter can be used.</p> <table border="1" data-bbox="304 671 738 868"> <thead> <tr> <th>Value</th> <th>Motor rotation direction</th> </tr> </thead> <tbody> <tr> <td>0</td> <td>(+) command, counter-clockwise rotation</td> </tr> <tr> <td>1</td> <td>(+) command, clockwise rotation</td> </tr> </tbody> </table>	Value	Motor rotation direction	0	(+) command, counter-clockwise rotation	1	(+) command, clockwise rotation	<p>0 ~ 1 【 0 】</p>														
Value	Motor rotation direction																						
0	(+) command, counter-clockwise rotation																						
1	(+) command, clockwise rotation																						
<p>28</p>	<p>Command pulse Input Type selection</p>	<p>This parameter is used to set the command pulse type given by the controller to the driver. There are three kinds of command pulse type showing as follows:</p> <table border="1" data-bbox="304 994 866 1329"> <thead> <tr> <th>value</th> <th>Command pulse type</th> <th>Signal name</th> <th>CCW command</th> <th>CW command</th> </tr> </thead> <tbody> <tr> <td>0</td> <td>Pulse/direction mode</td> <td>PLUS SIGN</td> <td></td> <td></td> </tr> <tr> <td>1</td> <td>CW/CCW pulse command mode</td> <td>PLUS SIGN</td> <td></td> <td></td> </tr> <tr> <td>2</td> <td>A/B pulse command mode</td> <td>PLUS SIGN</td> <td></td> <td></td> </tr> </tbody> </table>	value	Command pulse type	Signal name	CCW command	CW command	0	Pulse/direction mode	PLUS SIGN			1	CW/CCW pulse command mode	PLUS SIGN			2	A/B pulse command mode	PLUS SIGN			<p>0 ~ 2 【 0 】</p>
value	Command pulse type	Signal name	CCW command	CW command																			
0	Pulse/direction mode	PLUS SIGN																					
1	CW/CCW pulse command mode	PLUS SIGN																					
2	A/B pulse command mode	PLUS SIGN																					

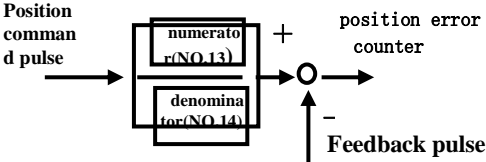
<p>29</p>	<p>Command Pulse input disable ineffective</p>	<p>This parameter determines the command pulse input disable signal (INH, Pin CN2-2) is effective or ineffective. When this parameter</p> <table border="1" data-bbox="304 243 682 366"> <tr> <td>Value</td> <td>INH input</td> </tr> <tr> <td>0</td> <td>effective</td> </tr> <tr> <td>1</td> <td>ineffective</td> </tr> </table> <p>is set to 1, even INH is low, the command pulse input is not disabled.</p>	Value	INH input	0	effective	1	ineffective	<p>0~1 【 1 】</p>
Value	INH input								
0	effective								
1	ineffective								
<p>31</p>	<p>Input command pulse frequency multiplication numerator</p>	<p>Command pulse frequency multiplication function (electrical gear)</p> <ul style="list-style-type: none"> <li>• Purpose:             <ol style="list-style-type: none"> <li>① This parameter can be used to set the corresponding motor speed or position for the unit input command pulse.</li> <li>② When the controller output frequency is not high enough to get the required speed reference, this parameter can be set to multiple the frequency to achieve higher command frequency.</li> </ol> </li> <li>• Division/ multiplication function diagram</li> </ul>  <ul style="list-style-type: none"> <li>• Electrical gear ratio setting range: <math>1/1800 \leq G \leq 1800</math></li> <li>• Electrical gear ratio recommended range: <math>1/100 \leq G \leq 100</math></li> </ul>	<p>1~9999 【 1 】</p>						
<p>32</p>	<p>Input command pulse frequency multiplication denominator</p>	<p><math>1/100 \leq G \leq 100</math></p>	<p>1~9999 【 1 】</p>						

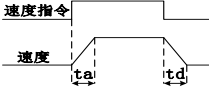
<p>34 ▲</p>	<p>Position command filtering coefficient</p>	<p>When position command frequency is divided or multiplied too many times, (more than 10 times or less than 1/10), this parameter is used to reduce the motor speed jump because of the frequency division or multiplication.</p> <table border="1" data-bbox="304 289 852 468"> <thead> <tr> <th>Value</th> <th>Time constant</th> </tr> </thead> <tbody> <tr> <td>0</td> <td>No filtering function</td> </tr> <tr> <td>1</td> <td>↓</td> </tr> <tr> <td>~</td> <td>Large time constant</td> </tr> <tr> <td>2048</td> <td>↓</td> </tr> </tbody> </table>	Value	Time constant	0	No filtering function	1	↓	~	Large time constant	2048	↓	<p>0~2048 【 0 】</p>
Value	Time constant												
0	No filtering function												
1	↓												
~	Large time constant												
2048	↓												
<p>37</p>	<p>Internal position register loop counter selection</p>	<p>The selection range for the internal position register loop counter is 1~16.</p>	<p>1~16 【 16 】</p>										
<p>39</p>	<p>Acceleration time constant (ms)</p>	<p>In speed control mode, the time duration for motor accelerating/decelerating from zero speed to the rated speed (ms).</p>  <p>(翻译左边图中的中文)</p>	<p>10~3000 【200】</p>										
<p>40</p>	<p>Deceleration time constant (ms)</p>	<p>(上面 speed reference) (下面 real speed)</p> <p>The larger the parameter is, the longer the time duration for accelerating/decelerating is; the smaller the parameter is, the shorter the time duration for accelerating/decelerating is.</p>	<p>10~3000 【200】</p>										

43	Speed command input gain	<ul style="list-style-type: none"> <li>• This parameter can be used to set the ratio between motor speed and analog speed reference voltage. ( Speed reference signal terminal is at pin CN2-33, signal ground is at CN2-35)</li> <li>• Speed control command = input voltage × parameter setting value;</li> <li>• No.43 default value is 200. For example, if analog input is 10V, then, the speed command is 2000rpm; If analog input is 5V, speed command is 1000rpm.</li> </ul>	10~500 【200】						
44	Speed command Input logic inverse	<p>When you want to change the motor rotation direction, but not change the analog speed reference polarity, this parameter can be used.</p> <table border="1" data-bbox="306 535 827 766"> <thead> <tr> <th data-bbox="306 535 362 632">Va lu e</th> <th data-bbox="362 535 827 571">Rotation direction</th> </tr> </thead> <tbody> <tr> <td data-bbox="306 632 362 699">0</td> <td data-bbox="362 632 827 699">(+) command, counter-clockwise rotation (viewed from the shaft)</td> </tr> <tr> <td data-bbox="306 699 362 766">1</td> <td data-bbox="362 699 827 766">(+) command, clockwise rotation(viewed from the shaft)</td> </tr> </tbody> </table>	Va lu e	Rotation direction	0	(+) command, counter-clockwise rotation (viewed from the shaft)	1	(+) command, clockwise rotation(viewed from the shaft)	0~1 【 0 】
Va lu e	Rotation direction								
0	(+) command, counter-clockwise rotation (viewed from the shaft)								
1	(+) command, clockwise rotation(viewed from the shaft)								
45	Speed command zero drift compensation	<ul style="list-style-type: none"> <li>• This parameter can be used to adjust the external analog speed reference zero-drift;</li> <li>• Changing every unit of this parameter can adjust 5mV of the drift.</li> </ul>	-2048~2048 【 0 】						
46	Torque command input gain	<ul style="list-style-type: none"> <li>• This parameter can be used to set the ratio between motor torque and analog torque reference voltage. (Torque reference signal terminal is at pin CN2-31. Signal ground is at CN-36)</li> <li>• Torque control command = input voltage × parameter setting value;</li> <li>• No.46 default value is 10. If input is 10V, torque control command is 100%; If input is 5V, torque control command is 50%.</li> </ul>	1~100 【10】						



47	Torque command input reverse	<p>This parameter can be set to change the torque reference input polarity.</p> <table border="1" data-bbox="303 197 845 361"> <thead> <tr> <th data-bbox="303 197 388 258">Value</th> <th data-bbox="388 197 845 258">Motor torque direction</th> </tr> </thead> <tbody> <tr> <td data-bbox="303 258 388 328">0</td> <td data-bbox="388 258 845 328">(+) command, counter-clockwise torque</td> </tr> <tr> <td data-bbox="303 328 388 361">1</td> <td data-bbox="388 328 845 361">(+) command, clockwise torque.</td> </tr> </tbody> </table>	Value	Motor torque direction	0	(+) command, counter-clockwise torque	1	(+) command, clockwise torque.	0~1 【0】
Value	Motor torque direction								
0	(+) command, counter-clockwise torque								
1	(+) command, clockwise torque.								
48	Torque limit setting	<ul style="list-style-type: none"> <li>This parameter is used to limit the maximum motor torque.</li> <li>Default value 200 means motor torque is limited within 200% of the rated torque.</li> </ul>	0~300 【200】						
50	Positioning complete range	<ul style="list-style-type: none"> <li>This parameter can be used to set the positioning complete signal (COIN, CN2-3) output time sequence, when motor arrives at the reference position given by the command pulse.</li> <li>When the rest of the position error counter number is within the value set by this parameter, the position complete signal will output.</li> </ul>	1~9999 【50】						
51	Zero speed	<ul style="list-style-type: none"> <li>This parameter is used to set the zero speed detection signal (ZSP, CN2-34) output time sequence.</li> <li>When motor speed is below the setting value, signal ZSP will be sent out.</li> </ul>	0~2000 【50】						
52	Speed arrival	<ul style="list-style-type: none"> <li>In speed and torque control mode, this parameter is used to set the speed arrival signal (COIN, CN2-3) output time sequence.</li> <li>When motor speed exceed the setting value, speed arrival signal will be sent out.</li> </ul>	0~3000 【2000】						
53	Position error overlarge setting	<ul style="list-style-type: none"> <li>This parameter can be used to set the threshold value for the position error overlarge.</li> <li>Parameter value = [Threshold value for position error overlarge (Pulse number)]/256</li> <li>If the position loop gain is small and the setting value of this parameter is also too small, position error overlarge protection (Alarm NO.9) will be activated even there is no position error.</li> </ul>	1~9999 【500】						

54	Position error overlarge protection ineffective	This parameter is used to disable the position error overlarge protection.		0~1 【 0 】
		Value	Position error overlarge protection	
		0	effective	
	1	Ineffective. Even if the pulse number exceeds the setting value of parameter No. 53, the motor will keep running.		

58	Mechanical brake Action time for motor stop	<ul style="list-style-type: none"> <li>• This parameter is used to define the process from mechanical brake break-off signal to motor current cutting off (servo idle) for motor stop.</li> <li>• After servo-ON signal is turning off, it takes about 6ms for software calculation, then BRK signal is sent out. As the mechanical brake has delay time, after time duration <math>T_a</math>, then, the brake will actually act. During this period, to avoid motor minor shift or the working panel falling off, the motor must be kept powered by electricity to maintain the torque. Only after the mechanical brake actually acts, the electricity can be turned off.</li> <li>• Value for this parameter should be larger than <math>T_a</math> (Mechanical brake delay time), to avoid motor minor shift or component falling off.</li> <li>• No. 58 = (Setting value) <math>\times</math> 2ms.</li> </ul> <div style="text-align: center;"> <p style="text-align: center;">上图中文字的翻译，逐行：  Servo-ON    effective            ineffective  BRK         Brake release    about 6ms    brake hold  Actual brake   Brake release   <math>T_a</math>    brake hold  Motor current   maintain electricity   No.58    idle(No electricity)</p> </div>	0~1000 【10】
----	---	--	----------------



<p>72 ※</p>	<p>232、485 commu nicat ion drive r setti ng</p>	<p>Select for the communication driver number, must agree with the upper-level controller setting.</p>	<p>0~255 【 0 】</p>										
<p>73 ※</p>	<p>232、485 commu nicat ion baud rate setti ng</p>	<table border="1" data-bbox="304 520 806 597"> <tr> <td>value</td> <td>0</td> <td>1</td> <td>2</td> <td>3</td> </tr> <tr> <td>Baud rate</td> <td>2400</td> <td>4800</td> <td>9600</td> <td>19200</td> </tr> </table>	value	0	1	2	3	Baud rate	2400	4800	9600	19200	<p>0~6 【 0 】</p>
value	0	1	2	3									
Baud rate	2400	4800	9600	19200									
<p>74 ※</p>	<p>232、485 commu nicat ion proto col setti ng</p>	<table border="1" data-bbox="304 770 806 917"> <tr> <td>0</td> <td>7bit, even parity check(e), 1 stop bit</td> </tr> <tr> <td>1</td> <td>7bit, odd parity check(o), 1 stop bit</td> </tr> <tr> <td>2</td> <td>7bit, no parity check(n), 2 stop bit</td> </tr> <tr> <td colspan="2">The setting of this parameter must agree with the settings of upper-level controller.</td> </tr> </table>	0	7bit, even parity check(e), 1 stop bit	1	7bit, odd parity check(o), 1 stop bit	2	7bit, no parity check(n), 2 stop bit	The setting of this parameter must agree with the settings of upper-level controller.		<p>0~8 【 6 】</p>		
0	7bit, even parity check(e), 1 stop bit												
1	7bit, odd parity check(o), 1 stop bit												
2	7bit, no parity check(n), 2 stop bit												
The setting of this parameter must agree with the settings of upper-level controller.													
<p>78</p>	<p>Torqu e comma nd filte r</p>	<ul style="list-style-type: none"> <li>• The bigger the setting value is, and the smoother the torque command is.</li> <li>• Too large value will slow down the response.</li> </ul>	<p>0~8100 【 0 】</p>										

83	Internal position command 1 speed setting	Internal position command (pulse number) = Internal position command setting value × pulse number per rotate + Internal position command pulse number setting value.	— 9999~ 9999 【 1 】
84	Internal position command 1 pulse number setting		— 9999~ 9999 【 1 】
85	Internal position command 2 speed setting	<div style="display: flex; justify-content: space-between;"> <span>—9999~9999</span> <span>【 1 】</span> </div> <div style="display: flex; justify-content: space-between;"> <span>—9999~9999</span> <span>【 1 】</span> </div>	
86	Internal position command 2 pulse number setting		
87	...3...		
88	...3...		
89	...		
90			
91			
92			
93			
94			
95			
96			
97			
98			
99			
100			
101			
102			

103		
104		
105		
106		
107		
108		
109		
110		
111		
112		
113		
114		
115	Internal position command 1 moving speed	
116	...2...	
117	...	
118		
119		
120		
121		
122		0~3000
123		【100】
124		
125		
126		
127		
128		
129		
130		
131	Internal speed command 1	
132	...2	Speed command proportion
133	...	setting value as No. 43
134		-3000~3000 【500】
135	Internal torque command 1	
136	...2	Torque command
137	...	proportion setting value
138		as No. 46
		-300~300 【50】

139	Delay register 1	Delay time form internal position command n to Internal position command n+1, delay time = setting value * 10ms 0~9999 【100】
140	...2	
141	...	
142		
143		
144		
145		
146		
147		
148		
149		
150		
151		
152		
153		
154		



## Chapter 5 Monitoring and Operation

### 5.1 Panel operation

The panel is composed of 5 LEDs and 4 buttons, “MOD” “←” “↑” and “SET”. It is used for displaying the system status and setting parameters.

The operation is based on different levels, which are described level by level as follows:

Level 1: It is used to select one of the 4 operating modes with the button “MOD”. Press “SET” to go into the second level. After typing the parameter number, press “SET” going into the third level and the parameter value can be changed. Button “MOD” can be used to return to the upper level when you are at level 2 or level 3. When setting the parameters, press “MOD”, the parameter value will not be changed. In short:

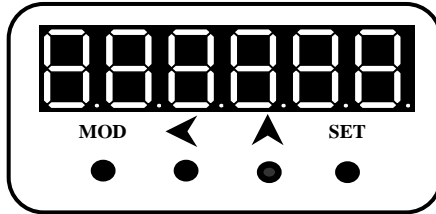

**“MOD”**: Mode selection/ cancellation

**“←”** : Shifting bit position

**“↑”** : Value increase

**“SET”** : Confirm

During operation, the bit where the decimal point is blinking indicates this bit can be modified.

If all 5 LEDs’ decimal points are blinking, there is alarm and the alarm number will be displayed.

If press the same button continuously, the following condition may happen:

Butt on	The condition may happen
MOD	Switching between different control modes or keeping going back to the upper level
←	Keep shifting the bit position to the left
↑	Increase the bit value without carry. When reaching 9, start from 0 again.

SET	If the operation is for EEPROM , it will keep writing EEPROM.
-----	---

The operation selection diagram is shown as follows:

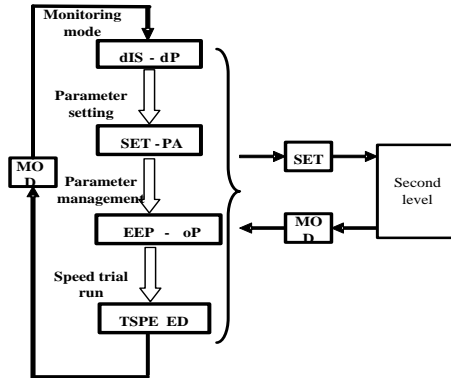

Fig. 5-1 Operation mode selection diagram (The first level)

## 5.2 Monitoring Mode (DISP)

1. Selecting monitoring mode “dISP” from the first level, press “SET” to enter the monitoring mode and LEDs display “dP0” .

2. In monitoring mode, there are 35 monitoring variables. Press “↑” to increase the value, press “←” to change the position. After choosing the needed display number, press “SET” to enter the specific display.

3. If you want to display other variables, press “SET” or “MOD” (In monitoring mode, these two buttons have the same function for return) to exit the present display and return to level 2.

4. If you want to go to other operation modes, press “MOD” , and it will go back to the upper level. When arriving at the first level, pressing “MOD” can switch between different modes.

5. If there is alarm, the decimal point right to the 5 LEDs will blink. It will not affect the button operation. When the alarm is clear, the display will return to normal.

In monitoring mode, the operation code and

corresponding display content is shown in Fig. 5.1.

Table 5.1 Status Display

Operati on code	Display content		Display example	Brief explanation
dP 0	Motor speed (r/min)		-1000	Motor reverse rotation speed 1000r/min
dP 1	Motor feedback pulse lower 4 bits		13C6	At current position, motor has accumulated 2F13C6 (hexadecimal) pulses in the reverse direction.
dP 2	Motor feedback pulse higher 4 bits		2F	
dP 3	Position command lower four bits (Pulse)		A023	Position command has accumulated 18A023 (hexadecimal) pulses in the forward direction.
dP 4	Position command higher 4 bits (Pulse)	→SET→ ←MOD← ←SET←	18	
dP 5	Position error (Pulse)		101	Position error has accumulated 101 pulses in the positive direction.
dP 6	Motor encoder lines		2500	Motor encoder has 2500-line resolution.
dP 7	Speed reference input		50	Speed reference is 50 (r/min)
dP 9	Torque reference input (%)		100	Torque reference input is 100%
dP 13	Motor average current (A)		4.2	Motor average phase current is 4.2A

dP 15	Command pulse frequency (kHz)		100	Position command pulse frequency is 100 kHz.
dP 16	Main circuit voltage (V)		330	Main circuit voltage is 330V.
dP 17	Rotor absolute position in a circle		1531	Rotor absolute position is 1531 in a circle (a full circle corresponding to 10000)
dP 18	Input terminal status		 	Input terminal signal, light indicates there is input at this bit.
dP 19	Output terminal signal			Output terminal signal, light indicates there is output at this bit.
dP 20	Encoder status			Encoder status, light indicates there is input at this bit.
dP 21	Control mode		C 1	Control mode is 1(speed control mode)
dP 22	Operation status		c n o n	Operation status : running
dP 23	Id		0	Current at field direction
dP 24	Iq		8192	Current at vertical to field direction, rated torque operation.
dP 25	Alarm record 1		E r r 01	Alarm record 1 is No. 1 alarm.
dP 26	Alarm record 2		E r r 01	Alarm record 2 is No. 1 alarm.
dP 27	Alarm record 3		E r r 01	Alarm record 3 is No. 1 alarm.
dP 28	Alarm record 4		E r r 01	Alarm record 4 is No. 1 alarm.

Note:

1. Input pulse is the one after the electrical gear.
2. Position command pulse frequency is the actual input pulse frequency before the electrical gear. The minimum unit is 0.1 kHz. Forward rotation is displayed by positive number, and reverse rotation is displayed by negative number.
3. Rotor absolute position represents the rotor position in a circle with respect to the stator. One round is a circle and the value range is 0~9999.
4. Operation status display:
  - “Cn oFF” : indicates the servo system is not running (Driver is not started, or there is alarm) .
  - “Cn on”: indicates the servo system is running.
5. Terminal input status is shown in Fig. 5-2 and output status is shown in Fig.5-3. Dotted lines at the upper part of the LEDs are the bits for monitoring the terminal status.

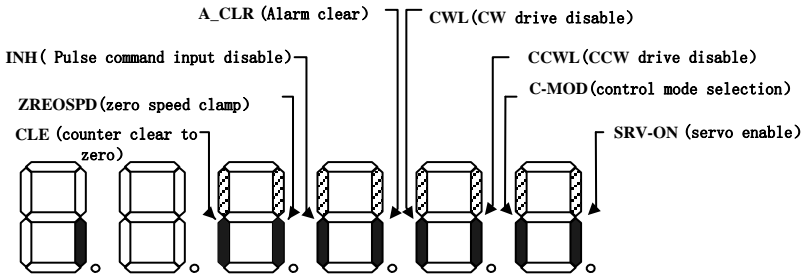

Fig. 5-2 Input terminal display (If the dotted line is on, it means the corresponding input terminal is ON. If the dotted line is off, it means the corresponding input terminal is OFF. )

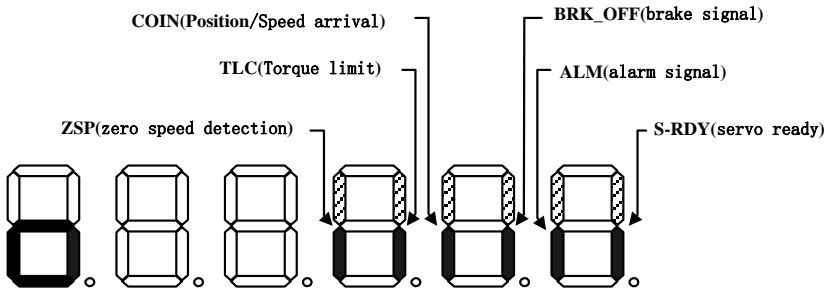

Fig. 5-3 Output terminal display (If the dotted line is on, it means the corresponding output terminal is ON. If the dotted line is off, it means the corresponding output terminal is OFF. )

---

### 5.3 Parameter setup (SET-P)

#### **【NOTE】**

- Before changing other parameters, parameter No.0 ( NO.0【Pass word】 ) must be set to be 58 first.
- Parameter setting will become effective immediately after change. ( Except for the parameters needed system re-power on ) . Wrong parameter setting may cause the abnormal function of the driver and cause accident.
- If the changed parameter is not written into EEPROM, it will not be saved after the system power-off.
- If the system lost power during the EEPROM written, please set the parameters again.

At the first level, select “SET-P”, press “SET” button to enter the parameter setting mode. Use “↑”、“←” button to choose the parameter number, then press “SET” to enter the parameter.

Use “↑”、“←” button to set up the parameter value. The decimal point of the right most LED will be blinking. Press “SET” to confirm the parameter change and it will come back to the upper level automatically.

If you are not satisfied with the parameter value, do not press “SET”, but press “MOD” to cancel this operation and return to the upper level. The parameter will remain the same value as before change.

After every change to the parameter value, please re-enter the parameter, double check and make sure the parameter value has been changed.

Note: In the parameter table, the parameter with “※” in front needs to be written into EEPROM after change and re-power on the system to let it effective.

### 5.4 Parameter management (EEPOP)



Parameter management deals with the operation between DSP RAM and EEPROM.

At the first level, select “EEPOP”, press “SET” button, then go into the parameter management mode.

Parameter management has 3 modes, use “↑” to select the mode number, then press “SET” to enter the corresponding parameter management.

Table 5.2 gives a brief explanation to the parameter management.

**Table 5.2 Parameter management**

Operation code	operation	Brief explanation	Corresponding relationship
EE-0	Parameter writing	<ul style="list-style-type: none"> <li>The parameter values in the RAM are written into EEPROM.</li> <li>If the user changes the parameter value, only the value stored in DSP’s RAM will change temporarily and will return to the original value after next power on. If want to change the parameter value permanently, you need to use this written command and the parameter will remain the changed value after next power on.</li> </ul>	RAM  EEPROM parameter region
EE-1	Parameter read	<ul style="list-style-type: none"> <li>Read all the parameters’ default value to the RAM and write them into EEPROM parameter region.</li> <li>During next power on, the default parameter values will be used. Please note, different driver version has different parameter values. Make sure the driver version is correct before using the default value.</li> </ul>	Parameter default value  RAM  EEPROM parameter region

The flowchart of parameter management is shown in Fig. 5-4.

- 
1. Press “MOD” button to display “EEPOP” .
  2. Press “SET” to enter the parameter management and select the operation code.  
The default operation is parameter writing (“EE-0”) .
  3. Press “SET” button again and LED displays “EEP -”. Keep pressing button “SET” .(About 4 seconds)
  4. When LED displays “Fnish” , indicating the operation is completed, release the button.

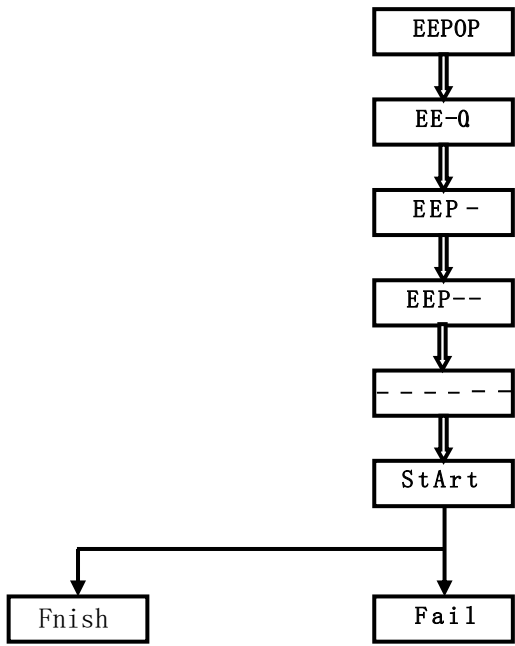

Fig. 5-4 Parameter management operation flowchart

- If you still keep pressing “SET” after the parameters written finished, the operation will start from step 3 again.
- If you release the button before “FInISH” is displayed, the operation will be cancelled automatically.

### 5.5 Speed trial run



- Make sure terminal TB and encoder terminal (CN3) is connected correctly and control terminal (CN2) is disconnected.
- Make sure selecting the correct **【Driver version selection】** parameter and other parameters. Load is removed from the motor shaft.
- After entering the trial run mode, you can press “MOD” to exit the trial run mode.
- Before exiting the trial run, please reduce the motor speed, otherwise, the motor will stop dramatically fast and may cause unexpected problems.
- If the servo enable signal (S-ON) is effective, it is impossible to enter trial run mode.
- If speed trial run is OK, meaning the motor and driver status is fine, the connection is good.
  - (1) At level 1, choose “t-SPd” .
  - (2) Press “SET” to enter the speed trial run mode and LEDs display “S-rdy” .
  - (3) Press “SET” to start speed trial run. The speed unit is r/min and the value can be set by button.
  - (4) Press “←” to increase the speed for reverse rotation and press “↑” to increase the speed for forward rotation. If you release the button, the motor will run at the setting speed.

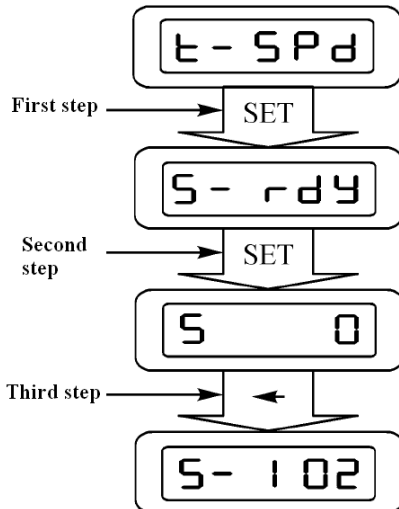

---

## Fig. 5-5 Speed trial run operation diagram

# Chapter 6 Alarm and handling

## 6.1 Driver alarm

S series driver has many protection functions. When one of the protections is triggered, the driver will turn off the output with a certain sequence and generate the alarm at the same time.

- When alarm occurs, LED panel will display an alarm number. The 5 LEDs' decimal points will blink and the servo-on signal is turned off.
- When alarm occurs, please shut off the power immediately and clear the fault according to the alarm number. If the problem is identified to be inside the driver, please contact our company for solution.

Table 6.1 Alarm overview

Alarm number	Alarm name	Brief reason
--	normal	
1	overload	Motor stator current is overlarge for a long time.
2	under voltage	Main circuit is under voltage.
3	Over voltage	Main circuit is over voltage.
4	Main circuit power losing phase	Main circuit only has signal phase power input.
8	Motor over-speed	Motor speed is over the rated value for a long time.
9	Position error over-large	Position error counter value exceed the threshold setting value.
11	Command pulse frequency abnormal	Command pulse frequency is higher than 500kpps.
12	Serial communication error	Serial communication error

14	CAN communication error	CAN communication error
16	EEPROM parameter error	EEPROM stored data is destroyed.
20	IPM alarm	IPM protection pin is always high.
21	Phase V current	The measured phase V current is too
22	Phase W current	The measured phase W current is too
23	Drive disable abnormal	Both clockwise and counter-clockwise position limit disable input are disconnected.
25	Encoder AB pulses missing	Encoder AB pulses are lost
26	Encoder Z pulse missing	Encoder Z pulse is lost
27	Encoder UVW signal is wrong	Encoder U、V、W signal is wrong
30	Speed tracking abnormal	The error between motor speed and speed reference is too large.

## 6.2 Alarm handling

The followings list several non-alarm failures and give some handling method to identify the problem.

### ▶ Motor can not run.

1. Parameter: Control mode selection is not proper.
2. Wire connection: Not receiving CN2 servo-on signal; CN2 counter clear zero is always effective(short circuit). CN2 command pulse input disable is effective——Monitoring input signal (dp 13) status via LED panel display, to identify the problem.
3. Shaft is locked permanently: Shut off the power, disconnect the motor, turn the motor shaft by hand to make sure the motor can rotate freely.

If the motor has lose-power brake, then, add a 24V DC power to the brake and try to turn the motor shaft by hand.

➤ **Rotation is not smooth.**

Wire connection:

- a) Servo- ON signal keeps appearing intermittently.
- b) CN2 CW/CCW signal keeps appearing intermittently.
- c) Counter clear signal is effective
- d) CN2 command pulse input disable signal is effective.

You can use LED panel to monitor input signal status (dp 13) to identify the problem.

➤ **Motor has noise or vibration.**

1. Parameter: The gain is too high: speed gain or position gain is too high; Speed detection filter is not set properly.
2. Installation: Machine and motor have resonance vibrations.

For every alarm, Table 6.3 gives some general handling methods.

Table 6.3 Alarm handling method

Number	Alarm name	Operation status	Alarm reason	Handling methods
1	Over load protection	<ul style="list-style-type: none"> <li>• During System acceleration or deceleration</li> <li>• During system running</li> </ul>	Driver has sampled overlarge current several times.	<ul style="list-style-type: none"> <li>① Increase the acceleration or deceleration time;</li> <li>② Make sure the driver version is compatible with the motor model.</li> <li>③ Replace the driver and motor with a larger power rating one.</li> </ul>

2	Main circuit under-voltage	<ul style="list-style-type: none"> <li>• During driver power-on</li> <li>• During system running</li> </ul>	Main circuit power converter dc-link voltage is below the setting value. .	<ul style="list-style-type: none"> <li>① Increase the main power transformer rating, increase the main power voltage;</li> <li>② Check the main power and control power connection time sequence.</li> </ul>
3	Main circuit over-voltage	<ul style="list-style-type: none"> <li>• During driver power-on</li> <li>• During system running</li> </ul>	Main power supply input voltage is higher than the rated acceptable voltage, which causes the dc-link voltage is higher than the rated value.	<ul style="list-style-type: none"> <li>① Measure the terminal voltage between (R、S and T ) to see whether it is within the range.</li> <li>② Check whether the braking resistor is broken.</li> </ul>
4	Main circuit power losing phase	<ul style="list-style-type: none"> <li>• During driver power-on</li> <li>• During system running</li> </ul>	R、T has no input power, or the input power is not enough.	Make sure the main power terminal is connected to 3-phase AC 220V power source or R、T terminal is connected to single phase AC220 power source.
8	Motor over-speed protection	<ul style="list-style-type: none"> <li>• During system running</li> </ul>	Motor speed exceeds the rated speed for a long time. .	<ul style="list-style-type: none"> <li>① Reduce the speed reference;</li> <li>② Make sure the motor model is selected correctly.</li> <li>③ Decrease parameter NO.43【Speed command input gain】 value;</li> <li>④ Make sure input pulse frequency × electrical</li> </ul>

				gear $\leq$ 500KHz.
9	Position error protection	<ul style="list-style-type: none"> <li>• During system running</li> </ul>	The number of position error pulses is larger than parameter NO.53 【 Position error over-large setting】 value.	<ul style="list-style-type: none"> <li>① Increase parameter NO.11【Position loop gain】 value;</li> <li>② Reduce the load and speed;</li> <li>③ Increase parameter NO.53 【 Position error over-large setting 】 value.</li> </ul>
11	Command pulse frequency abnormal	<ul style="list-style-type: none"> <li>• During system running</li> </ul>	The command pulse frequency at the input of position error counter is larger than 500kpps.	<ul style="list-style-type: none"> <li>① Set the proper command pulse input frequency;</li> <li>② Adjust parameter No. 31、 32 value , reduce the multiplication coefficient, to let the command pulse frequency be lower than 500 kpps. ( Command pulse frequency = input command frequency <math>\times</math> division/multiplication coefficient)</li> </ul>
12	Serial communication error	<ul style="list-style-type: none"> <li>• During communication</li> </ul>	The driver received data is found out to be different from the one upper-level controller has sent after CRT check.	<ul style="list-style-type: none"> <li>① Check the communication line;</li> <li>② Check the baud rate and serial port parameters setting;</li> <li>③ Communication chip failure inside the driver</li> </ul>

16	<b>EEPROM parameter error</b>	<ul style="list-style-type: none"> <li>• During driver power-on</li> <li>• During parameter management operation</li> </ul>	The data stored in EEPROM are destroyed.	Re-set the parameters or re-write the default parameter values. If this alarm happens frequently, the driver may have problem.
19	<b>Driver version selection error</b>	<ul style="list-style-type: none"> <li>• During driver power-on</li> </ul>	Driver version number is not within the given range.	Re-set the driver motor model selection parameter.
20	<b>IPM alarm</b>	<ul style="list-style-type: none"> <li>• During driver power-on</li> </ul>	Driver power module is damaged.	<p>① Check whether motor power line and encoder line are connected properly;</p> <p>② Check whether the driver motor model selection parameter is correct.</p> <p>③ Check whether the driver IPM module is ok; After checking, re-power on the system, if the alarm No.20 still exists, please contact our company.</p>
21	<b>Phase V current abnormal</b>	<ul style="list-style-type: none"> <li>• During driver power-on</li> </ul>	The reason could be unstable power supply, current sensor damage or AD sampling circuit damage which causes	Driver power supply damage or other damage inside the driver.
22	<b>Phase W current</b>			

	<b>abnormal</b>		the sampling error.	
23	Drive disable abnormal 1	• During system running	Clockwise and counter-clockwise position limit disable inputs are both disconnected.	① Check the related circuit wiring and power. ② Check parameter NO.06 value.
24	<b>PWM error</b>	• During system running	PWM output waveform abnormal caused by power supply or IPM module damage.	① Check whether there is noise source near the input power and around. ② If this error happens frequently, the driver may have problem.
25	<b>Encoder AB pulse missing</b>	• During system running	There is no Phase-A, B signal between driver and encoder, or the encoder has sent the wrong data.	① Check the encoder connection wire. ② Do not put the encoder wire and motor cable together, connect the shielding wire to the motor cover. ③ Increase the acceleration and deceleration time
26	Encoder Z pulse missing	• During system running	Z pulse signal generated once every circle is not detected.	① Check the cable connection, don't put the encoder signal wire together with the motor cable. ② Increase acceleration and deceleration time. ③ Replace the servo motor.



27	Encoder U、V、 W signal error	<ul style="list-style-type: none"> <li>• During driver power-on</li> <li>• During system running</li> </ul>	The detected encoder U、V、W signal is ineffective. They are 0 or 1 at the same time.	<ul style="list-style-type: none"> <li>① Check the encoder wire</li> <li>② Replace the servo motor</li> <li>③ Replace the driver</li> </ul>
30	Speed tracking abnormal	<ul style="list-style-type: none"> <li>• During driver power-on</li> <li>• During system running</li> </ul>	Motor speed can not track the speed reference for a long time.	<ul style="list-style-type: none"> <li>① Check whether the load mechanical part is locked;</li> <li>② Check whether the motor power line and encoder line is connected properly;</li> <li>③ Check whether the driver IPM module is ok; After checking, re-power on the system, if the same No. 30 alarm happens, please contact the company.</li> </ul>

**[Note]**

◆ Explanation: “During diver power-on” means the servo system is under disabled condition (S-ON ineffective);

“During system running” means the servo system is under enabled condition (S-ON effective) .

## Chapter 7 Servo motor

### 【NOTE】

- Servo driver must be compatible with the motor.
- Motor winding U、V、W phase sequence should agree with the driver terminal.
- Servo motor has precise feedback devices inside. Knocking or strong vibration is prohibited during transportation and installation.
- If the user wants to choose the servo motor from other companies, please notified us in the order and we will try our best to meet your requirement.

#### 7.1 Model naming format

Motor model name is composed of frame number, product number and performance specs number:

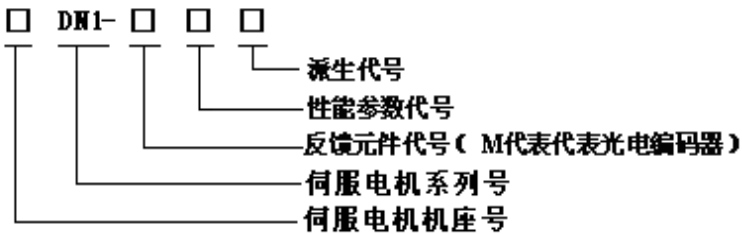

由上到下:

Extension code

Performance specs number

Feedback device number (M represents optical encoder)

Servo motor serial number

Servo motor frame number

Motor frame number is: 40、60、80、90、110、130.

Feedback device number: M - optical pulse encoder.

Performance specs number: Upper 3 digits represent rated torque.

Lower 2 digits represent rated speed.

For example, if the performance specs number is 02030, it represents rated torque is 2N·m and rated speed is 3000rpm.

Extension code: Z- lose-power brake

**1. Parameters list of 60 serial servo motors**

Motor model	60DN1-M00130		60DN1-M00230		60DN1-M00330				
Rated power (KW)	0.03		0.05		0.1				
Rated speed (rpm)	3000		3000		3000				
Rated torque (N.m)	0.0955		0.159		0.318				
Maximum torque (N.m)	0.287		0.477		0.954				
Electric potential coefficient (Vs/rad)	0.108		0.127		0.127				
Torque coefficient (N.m/A)	0.108		0.127		0.127				
Rotor inertia (Kg.m <sup>2</sup> )	1.31×10 <sup>-6</sup>		2.11×10 <sup>-6</sup>		4.11×10 <sup>-6</sup>				
Motor model	60DN1-M00630		60DN1-M01330		60DN1-M01930				
Rated power (KW)	0.2		0.4		0.6				
Rated speed (rpm)	3000		3000		3000				
Rated torque (N.m)	0.637		1.27		1.91				
Maximum torque (N.m)	1.911		3.8		5.73				
Electric potential coefficient (Vs/rad)	0.5		0.5		0.5				
Torque coefficient (N.m/A)	0.5		0.5		0.5				
Rotor inertia (Kg.m <sup>2</sup> )	0.167×10 <sup>-4</sup>		0.26×10 <sup>-4</sup>		0.438×10 <sup>-4</sup>				
Encoder lines (PPR)	2500								
Motor insulation level	Class F (155℃)								
Prevention level	IP65								
Using environmental	Environmental temperature: -20℃ ~ +50℃ Environmental moisture: relative moisture<90% (No frosting condition)								
Motor winding socket	Winding lines	U		V		W		PE	
	Socket number	3		2		4		1	
Encoder socket	Signal lines	5V	0V	A+	A-	B+	B-	Z+	Z-
	Socket number	2	3	4	5	6	7	8	9
	Signal lines	U+	U-	V+	V-	W+	W-	PE	
	Socket number	10	11	12	13	14	15	1	

2、Parameters list of 80 serial servo motors

Motor model	80DN1-M01630		80DN1-M02430		80DN1-M03230				
Rated power (KW)	0.5		0.75		1				
Rated speed (rpm)	3000		3000		3000				
Rated torque (N.m)	1.59		2.39		3.18				
Maximum torque (N.m)	4.77		7.16		9.549				
Electric potential coefficient (Vs/rad)	0.5		0.5		0.5				
Torque coefficient (N.m/A)	0.5		0.5		0.5				
Rotor inertia (Kg.m <sup>2</sup> )	0.138×10 <sup>-4</sup>		0.3×10 <sup>-4</sup>		0.384×10 <sup>-4</sup>				
Encoder lines (PPR)	2500								
Motor insulation level	Class F (155°C)								
Prevention level	IP65								
Using environmental	Environmental temperature: -20°C ~ +50°C Environmental moisture: relative moisture<90% (No frosting condition)								
Motor winding socket	Winding lines	U		V		W		PE	
	Socket number	3		2		4		1	
Encoder socket	Signal lines	5V	0V	A+	A-	B+	B-	Z+	Z-
	Socket number	2	3	4	5	6	7	8	9
	Signal lines	U+	U-	V+	V-	W+	W-	PE	
	Socket number	10	11	12	13	14	15	1	

3、Parameters list of 90/110 serial servo motors

Motor model	90DN1-M02430		110DN1-M02030		110DN1-M04030				
Rated power (KW)	0.75		0.6		1.2				
Rated speed (rpm)	3000		3000		3000				
Rated torque (N.m)	2.39		2		4				
Maximum torque (N.m)	7.16		6		12				
Electric potential coefficient (Vs/rad)	43		57		54				
Torque coefficient (N.m/A)	0.5		0.8		0.8				
Rotor inertia (Kg.m <sup>2</sup> )	0.3×10 <sup>-4</sup>		0.31×10 <sup>-3</sup>		0.54×10 <sup>-3</sup>				
Motor model	110DN1-M05030		110DN1-M06020		110DN1-M06030				
Rated power (KW)	1.5		1.2		1.6				
Rated speed (rpm)	3000		2000		3000				
Rated torque (N.m)	5		6		6				
Maximum torque (N.m)	15		12		18				
Electric potential coefficient (Vs/rad)	62		83		61				
Torque coefficient (N.m/A)	0.83		1.33		1.0				
Rotor inertia (Kg.m <sup>2</sup> )	0.63×10 <sup>-3</sup>		0.76×10 <sup>-3</sup>		0.76×10 <sup>-3</sup>				
Encoder lines (PPR)	2500								
Motor insulation level	Class F (155℃)								
Prevention level	IP65								
Using environmental	Environmental temperature: -20℃ ~ +50℃ Environmental moisture: relative moisture<90% (No frosting condition)								
Motor winding socket	Winding lines	U		V		W		PE	
	Socket number	3		2		4		1	
Encoder socket	Signal lines	5V	0V	A+	A-	B+	B-	Z+	Z-
	Socket number	2	3	4	5	6	7	8	9
	Signal lines	U+	U-	V+	V-	W+	W-	PE	
	Socket number	10	11	12	13	14	15	1	

4、Parameters list of 130 serial servo motors

Motor model	130DN1-M04025	130DN1-M05025	130DN1-M06025	130DN1-M07725					
Rated power (KW)	1.0	1.3	1.5	2.0					
Rated speed (rpm)	2500	2500	2500	2500					
Rated torque (N.m)	4	5.0	6	7.7					
Maximum torque (N.m)	12	15	18	22					
Electric potential coefficient (Vs/rad)	69.3	68	63	66					
Torque coefficient (N.m/A)	1.0	1.0	1.0	1.03					
Rotor inertia (Kg.m <sup>2</sup> )	$0.85 \times 10^{-3}$	$1.06 \times 10^{-3}$	$1.26 \times 10^{-3}$	$1.53 \times 10^{-3}$					
Motor model	130DN1-M10015	130DN1-M10025	130DN1-M015015	130DN1-M15025					
Rated power (KW)	1.5	2.6	2.3	3.8					
Rated speed (rpm)	1500	2500	1500	2500					
Rated torque (N.m)	10	10	15	15					
Maximum torque (N.m)	25	25	30	30					
Electric potential coefficient (Vs/rad)	101	69	112	66					
Torque coefficient (N.m/A)	1.67	1.0	1.58	0.88					
Rotor inertia (Kg.m <sup>2</sup> )	$1.94 \times 10^{-3}$	$1.94 \times 10^{-3}$	$2.77 \times 10^{-3}$	$2.77 \times 10^{-3}$					
Encoder lines (PPR)	2500								
Motor insulation level	Class F (155°C)								
Prevention level	IP65								
Using environmental	Environmental temperature: -20°C ~ +50°C Environmental moisture: relative moisture<90% (No frosting condition)								
Motor winding socket	Winding lines	U		V		W		PE	
	Socket number	3		2		4		1	
Encoder socket	Signal lines	5V	0V	A+	A-	B+	B-	Z+	Z-
	Socket number	2	3	4	5	6	7	8	9
	Signal lines	U <sub>+</sub> • U <sub>-</sub> •		V+	V-	W+	W-	PE	
	Socket number	10	11	12	13	14	15	1	

## 7.2 Motor installation dimension

1、60/80/90 serial Servo motor installation dimension: Unit (mm)

	60 serial					80 serial				90 serial
Rated torque (N • m)	0.0955	0.159	0.318	0.637	1.27	1.91	1.59	2.39	3.18	2.39
LA	85	93	113	96	122	146	129	147	165	190
LB	20	20	20	31	31	31	35	35	35	35
LC	1.5	1.5	1.5	3	3	3	3	3	3	3
LD	8	8	8	7	7	7	13	13	13	13
LE	38	38	38	50	50	50	70	70	70	80
LF	60	60	60	60	60	60	80	80	80	86
LG	66.5	66.5	66.5	70	70	70	90	90	90	100
LZ	5.5	5.5	5.5	4.5	4.5	4.5	5.5	5.5	5.5	6.5
S	8	8	8	14	14	14	19	19	19	16

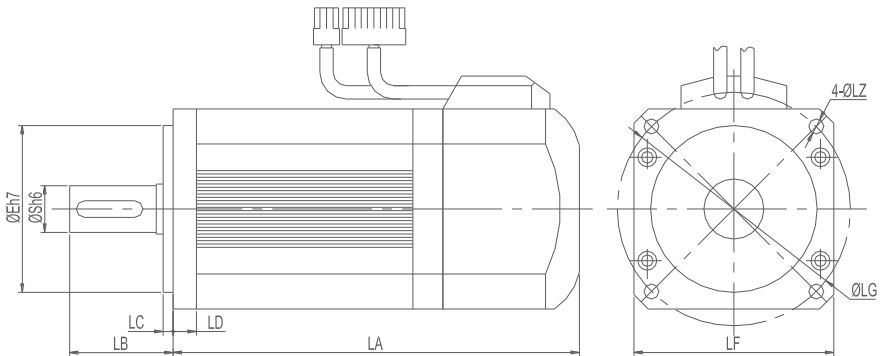



2、110/130 serial Servo motor installation dimension: Unit (mm)

Rated torque (N • m)	110 serial				130 serial					
	2	4	5	6	4	5	6	7.7	10	15
LA	157	187	202	217	164	173	182	196	217	260
LB	55	55	55	55	57	57	57	57	57	57
LC	5	5	5	5	5	5	5	5	5	5
LD	12	12	12	12	14	14	14	14	14	14
LE	95	95	95	95	110	110	110	110	110	110
LF	110	110	110	110	130	130	130	130	130	130
LG	130	130	130	130	145	145	145	145	145	145
LZ	9	9	9	9	9	9	9	9	9	9
S	19	19	19	19	22	22	22	22	22	22

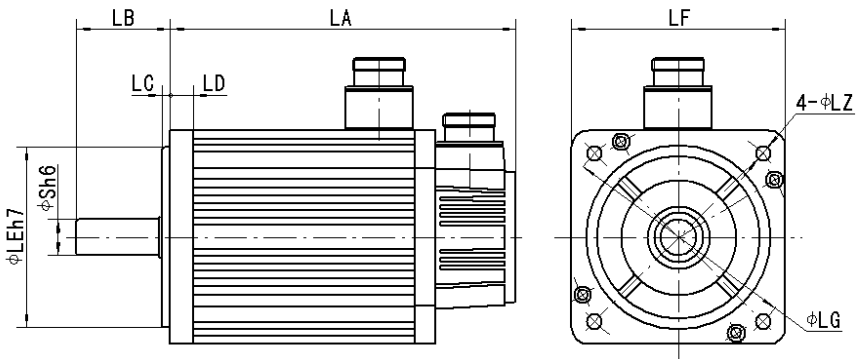

---

## Appendix

### 1. Motor power calculation

Based on motor rated speed and rated torque, the servo motor power can be calculated by the following equation:

$$W = \frac{2\pi}{60} NM$$

W: Motor power, unit: W;

M: Motor torque, unit : Nm;

N: Motor speed, unit: rpm。

For example: 130ST-M10015 motor, its torque is 10N·M and speed is 1500rpm;

Based on the above equation, the power is:  $W=(10 \times 1500) \times 2 \times 3.14 \div 60 \div 1000=1.57$  (KW)

### 2. electrical gear ratio

The meaning of electrical gear ratio and its adjustment method:

In position control mode, the load actual speed is:

Command pulse speed  $\times G \times$  mechanical reduction gear ratio

In the diver with mechanical gears, the electrical gear ratio G is calculated by the following equation:

$$G = \frac{P_{\text{pulse}} \times M \times i}{L}$$

**P<sub>pulse</sub>** : The number of pulses for every motor cycle; it represents the number of pulses feed back by feedback device for the motor rotating one round. For a 2500 pulse incremental encoder, the number of pulses feed back to the driver is  $2500 \times 4=10000$  a round;

M: Pulse calculation equivalent (mm). It refers to the upper-level controller resolution;

L: Lead screw pitch (mm);

i: Mechanical gear ratio  
i=  $\frac{\text{driven gear teeth number (machine side)}}{\text{driving gear teeth number(motor side)}}$

For example: If the upper-level controller pulse equivalent is 0.001mm; Mechanical reduction gear ratio is  $i = \text{driven gear} / \text{driving gear} = 36 / 24$ ; Lead screw pitch is 6mm; Motor encoder is 2500P/r, the number of encoder feedback pulses per round is  $2500 \times 4 = 10000$ .  
Based on the above equation:

$$G = \frac{10000 \times 0.001 \times \frac{36}{24}}{6} = \frac{5}{2}$$

### [Note]

- When the electrical gear ratio is not 1, there may be remainder after division operation. In this case, there will be position error; the maximum error will be motor minimum movement. (Minimum resolution 1/10000 per round )
- For direct connection (without mechanical gear), the calculation will be the same as above except that the mechanical gear ratio is  $i=1$ .

This manual is not an assurance for the industrial proprietary or other proprietaries and not a promise to any execution right. In addition, for the issues concerning the industrial proprietary caused by using this manual, our company will not be responsible